



SYLLABUS

DIPLOMA IN AUTOMOBILE ENGINEERING

COURSE CODE: 1021

2015-2016

M - SCHEME

**DIRECTORATE OF TECHNICAL EDUCATION
GOVERNMENT OF TAMILNADU**

**STATE BOARD OF TECHNICAL EDUCATION & TRAINING,
TAMILNADU
DIPLOMA IN ENGINEERING / TECHNOLOGY SYLLABUS
M SCHEME**

(Implemented from the Academic year 2015 - 2016 onwards)

CHAIRPERSON

Tmt. S.MADUMATHI, I.A.S.,

Director
Directorate of Technical Education
Guindy, Chennai.

Dr. K.SUNDARAMOORTHY, M.E., Ph.D.,

Additional Director of Technical Education (Polytechnics)
Directorate of Technical Education
Guindy, Chennai.

Co-ordinator

Dr. M.Isakkimuthu, Ph.D.,
Principal
Bharathiar Centenary Memorial Girls
Government Polytechnic College,
Ettayapuram-628902

Convener

Thiru. S.Mohan., M.E.,
Principal Incharge
P.T.Lee Chengalvaraya Naicker
Polytechnic College,
Vepery, Chennai -600007

MEMBERS

Dr. K. Annamalai, Ph.D., Associate Professor, Faculty of Automobile Engineering Madras Institute of Technology Anna University, Chennai-44	Thiru.S.Saravanan, M.E.,M.B.A., Workshop Superintendent (Sel.Gr.) P.T.Lee Chengalvaraya Naicker Polytechnic College, Vepery, Chennai -600007
Dr. K. Chinnaraj, Ph.D., AGM/Product Development Ashok Leyland Technical centre Chennai	Thiru.N.Thirunavukkarasu, M.E., Lecturer / Mechanical Central Polytechnic College, Tharamani, Chennai-113
Thiru. P.S.Surendran, General Manager/ Services Chandra Hyundai Automobile Ltd, Coimbatore.	Thiru. C. Venkatesan.,M.E., Head of the Department/ Automobile V. Ramakrishna Polytechnic College, Thiruvottiyur, Chennai.
Thiru. A.Periasamy,M.E., Head of the Department (i/c)/Mechanical P.T.Lee Chengalvaraya Naicker Polytechnic College, Vepery, Chennai -600007	Thiru. S. Mohanbabu.,B.E., Lecturer/ Automobile Ramakrishna Mission Polytechnic College, Mylapore, Chennai -4.

DIPLOMA COURSES IN ENGINEERING/TECHNOLOGY

(SEMESTER SYSTEM)

(Implemented from 2015- 2016)

M – SCHEME

REGULATIONS*

* *Applicable to the Diploma Courses other than Diploma in Hotel Management & Catering Technology and the Diploma Courses offered through MGR Film Institute, Chennai.*

1. Description of the Course:

a. Full Time (3 years)

The Course for the full Time Diploma in Engineering shall extend over a period of three academic years, consisting of 6 semesters* and the First Year is common to all Engineering Branches.

b. Sandwich (3½ years)

The Course for the Diploma in Engineering (sandwich) shall extend over a period of three and half academic years, consisting of 7 semesters* and the First Year is common to all Engineering Branches. The subjects of three years full time diploma course being regrouped for academic convenience.

During 4th and/or during 7th semester the students undergo industrial training for six months/ one year. Industrial training examination will be conducted after completion of every 6 months of industrial training

c. Part Time (4 years)

The course for the diploma in Engineering shall extend over a period of 4 academic years containing of 8 semesters*, the subjects of 3 year full time diploma courses being regrouped for academic convenience.

* Each Semester will have 15 weeks duration of study with 35 hrs. /Week for Regular Diploma Programme and 18hrs/ week (21 hrs. / Week I year) for Part-Time Diploma Programmes.

The Curriculum for all the 6 Semesters of Diploma courses (Engineering & Special Diploma Courses viz. Textile Technology, Leather Technology, Printing Technology, Chemical Technology etc.) have been revised and revised curriculum is applicable for the candidates admitted from 2015 – 2016 academic year onwards.

2. Condition for Admission:

Condition for admission to the diploma courses shall be required to have passed in

The S.S.L.C Examination of the Board of Secondary Education, TamilNadu.

(Or)

The Anglo Indian High School Examination with eligibility for Higher Secondary Course in TamilNadu.

(Or)

The Matriculation Examination of Tamil Nadu.

(Or)

Any other Examination recognized as equivalent to the above by the Board of Secondary Education, TamilNadu.

Note: In addition, at the time of admission the candidate will have to satisfy certain minimum requirements, which may be prescribed from time to time.

3. Admission to Second year (Lateral Entry):

A pass in HSC (Academic) or (Vocational) courses mentioned in the Higher Secondary Schools in TamilNadu affiliated to the TamilNadu Higher Secondary Board with eligibility for university Courses of study or equivalent examination, & Should have studied the following subjects.

Sl. No	Courses	H.Sc Academic	H.Sc Vocational	
		Subjects Studied	Subjects Studied	
			Related subjects	Vocational subjects
1.	All the Regular and Sandwich Diploma Courses	Maths, Physics & Chemistry	Maths / Physics / Chemistry	Related Vocational Subjects Theory & Practical
2.	Diploma course in Modern Office Practice	English & Accountancy English & Elements of Economics English & Elements of Commerce	English & Accountancy, English & Elements of Economics, English & Management Principles & Techniques, English & Typewriting	Accountancy & Auditing, Banking, Business Management, Co-operative Management, International Trade, Marketing & Salesmanship, Insurance & Material Management, Office Secretaryship.

- For the diploma Courses related with Engineering/Technology, the related / equivalent subjects prescribed along with Practical may also be taken for arriving the eligibility.
- Branch will be allotted according to merit through counseling by the respective Principal as per communal reservation.
- For admission to the Textile Technology, Leather Technology, Printing Technology, Chemical Technology and Modern Office Practice Diploma courses the candidates studied the related subjects will be given first preference.
- *Candidates who have studied Commerce Subjects are not eligible for Engineering Diploma Courses.*

4. Age Limit: No Age limit.

5. Medium of Instruction: English

6. Eligibility for the Award of Diploma:

No candidate shall be eligible for the Diploma unless he/she has undergone the prescribed course of study for a period of not less than 3 academic years in any institution affiliated to the State Board of Technical Education and Training, TamilNadu, when joined in First Year and two years if joined under Lateral Entry scheme in the second year and passed the prescribed examination.

The minimum and maximum period for completion of Diploma Courses are as given below:

Diploma Course	Minimum Period	Maximum Period
Full Time	3 Years	6 Years
Full Time(Lateral Entry)	2 Years	5 Years
Sandwich	3½ Years	6½ Years
Part Time	4 Years	7 Years

7. Subjects of Study and Curriculum outline:

The subjects of study shall be in accordance with the syllabus prescribed from time to time, both in theory and practical. The curriculum outline is given in Annexure - I

8. Examinations:

Board Examinations in all subjects of all the semesters under the scheme of examinations will be conducted at the end of each semester.

The Internal assessment marks for all the subjects will be awarded on the basis of continuous internal assessment earned during the semester concerned. For each subject 25 marks are allotted for internal assessment and 75 marks are allotted for Board Examination.

9. Continuous Internal Assessment:

A . For Theory Subjects:

The Internal Assessment marks for a total of 25 marks, which are to be distributed as follows:

i. Subject Attendance

5 Marks

(Award of marks for subject attendance to each subject theory/practical will as per the range given below)

80% - 83%	}	1 Mark
84% - 87%		2 Marks
88% - 91%		3 Marks
92% - 95%		4 Marks
96% - 100%		5 Marks

ii) Test #

10 Marks

2 Tests each of 2 hours duration for a total of 50 marks are to be conducted. Out of which the best one will be taken and the marks to be reduced to: 05 marks

The Test – III is to be the Model test covering all the five units and the marks so obtained will be reduced to : 05 marks

Total **10 marks**

TEST	UNITS	WHEN TO CONDUCT	MARKS	DURATION
Test I	Unit – I & II	End of 6 th week	50	2 Hrs
Test II	Unit – III & IV	End of 12 th week	50	2 Hrs
Test III	Model Examination - Compulsory Covering all the 5 Units. (Board Examination-question paper-pattern).	End of 15 th week	75	3 Hrs

- From the Academic year 2015-2016 onwards.

Question Paper Pattern for the Periodical Test :(Test - I & Test- II)

With no choice:

PART A type questions:	4 Questions X 2 mark	8 marks
PART B type questions:	4 Questions X 3 marks	12 marks
PART C type questions:	3 Questions X 10 marks	30 marks

	Total		50 marks

iii) Assignment

10 Marks

For each subject Three Assignments are to be given each for 20 marks and the average marks scored should be reduced for 10 marks

All Test Papers and assignment notebooks after getting the signature with date from the students must be kept in the safe custody in the Department for verification and audit. It should be preserved for 2 Semesters and produced to the flying squad and the inspection team at the time of inspection/verification.

B. For Practical Subjects:

The internal assessment mark for a total of 25 marks which are to be distributed as follows:-

a)	Attendance	:	5 Marks
	(Award of marks as same as Theory subjects)		
b)	Procedure/ observation and tabulation/ Other Practical related Work	:	10 Marks
c)	Record writing	:	10 Marks

	TOTAL	:	25 Marks

- *All the Experiments/exercises indicated in the syllabus should be completed and the same to be given for final board examinations.*
- The Record for every completed exercise should be submitted in the subsequent Practical classes and marks should be awarded for 20 for each exercise as per the above allocation.
- At the end of the Semester, the average marks of all the exercises should be calculated for 20 marks and the marks awarded for attendance is to be added to arrive at the internal assessment mark for Practical. (20+5=25 marks)
- The students have to submit the duly signed bonafide record note book/file during the Practical Board Examinations.

- All the marks awarded for assignment, Test and attendance should be entered in the Personal Log Book of the staff, who is handling the subject. This is applicable to both Theory and Practical subjects.

10. Life and Employability Skill Practical:

The Life and Employability Skill Practical with more emphasis is being introduced in IV Semester for Circuit Branches and in V Semester for other branches of Engineering.

Much Stress is given to increase the employability of the students:

Internal assessment Mark **25 Marks**

11. Project Work:

The students of all the Diploma Programmes (**except Diploma in Modern Office Practice**) have to do a Project Work as part of the Curriculum and in partial fulfillment for the award of Diploma by the State Board of Technical Education and Training, Tamilnadu. In order to encourage students to do worthwhile and innovative projects, every year prizes are awarded for the best three projects i.e. institution wise, region wise and state wise. **The Project work must be reviewed twice in the same semester.**

a) Internal assessment mark for Project Work & Viva Voce:

Project Review I	...	10 marks
Project Review II	...	10 marks
Attendance	...	05 marks (award of marks same as theory subjects pattern)

Total	...	25 marks

Proper record to be maintained for the two Project Reviews, and It should be preserved for 2 Semesters and produced to the flying squad and the inspection team at the time of inspection/verification.

b) Allocation of Mark for Project Work & Viva Voce in Board Examination:

Viva Voce	...	30 marks
Marks for Report Preparation, Demo	...	35 marks

Total		65 marks

c) Written Test Mark (from 2 topics for 30 minutes duration): \$

i) Environment Management	2 questions X 2 ½ marks	= 5 marks
ii) Disaster Management	2 questions X 2 ½ marks	= 5 marks

		10marks

\$ - Selection of Questions should be from Question Bank, by the External Examiner.

No choice need be given to the candidates.

Project Work & Viva Voce in Board Examination	--	65 Marks
Written Test Mark (from 2 topics for 30 minutes duration)	--	10 Marks
TOTAL	--	75 Marks

A neatly prepared PROJECT REPORT as per the format has to be submitted by individual during the Project Work & Viva Voce Board examination.

12. Scheme of Examinations:

The Scheme of examinations for subjects is given in **Annexure - II**.

13. Criteria for Pass:

1. No candidate shall be eligible for the award of Diploma unless he/she has undergone the prescribed course of study successfully in an institution approved by AICTE and affiliated to the State Board of Technical Education & Training, Tamil Nadu and pass all the subjects prescribed in the curriculum.
2. A candidate shall be declared to have passed the examination in a subject if he/she secures not less than *40% in theory subjects* and *50% in practical subject* out of the total prescribed maximum marks including both the internal assessment and the Board Examination marks put together, subject to the condition that he/she secures at least a minimum of *30 marks out of 75 marks in the Board's Theory examinations and a minimum of 35 marks out of 75 marks in the Board Practical Examinations.*

14. Classification of successful candidates:

Classification of candidates who will pass out the final examinations from April 2018 onwards (Joined in first year in 2015-2016) will be done as specified below.

First Class with Superlative Distinction:

A candidate will be declared to have passed in **First Class with Superlative Distinction** if he/she secures not less than 75% of the marks in all the subjects and passes all the semesters in the first appearance itself and passes all subjects within the stipulated period of study 3/ 3½/ 4 years (Full Time/Sandwich/Part Time) without any break in study.

First Class with Distinction:

A candidate will be declared to have passed in **First Class with Distinction** if he/she secures not less than 75% of the aggregate of marks in all the

semesters put together and passes all the semesters except the I and II semesters in the first appearance itself and passes all the subjects within the stipulated period of study 3/ 3½/ 4 years (Full Time/Sandwich/Part Time) without any break in study.

First Class:

A candidate will be declared to have passed in **First Class** if he/she secures not less than 60% of the aggregate marks in all semesters put together and passes all the subjects within the stipulated period of study 3/ 3½ / 4 years (Full Time/Sandwich/Part Time) without any break in study.

Second Class:

All other successful candidates will be declared to have passed in **Second Class**.

The above mentioned classifications are also applicable for the Sandwich / Part-Time students who pass out Final Examination from October 2018 /April 2019 onwards (both joined in First Year in 2015-2016)

15. Duration of a period in the Class Time Table:

The duration of each period of instruction is 1 hour and the total period of instruction hours excluding interval and Lunch break in a day should be uniformly maintained as 7 hours corresponding to 7 periods of instruction (Theory & Practical).

16. Seminar:

For seminar the total seminar 15 hours(15 weeks x 1hour) should be distributed equally to total theory subject per semester(i.e 15 hours divided by 3/4 subject). A topic from subject or current scenario is given to students. During the seminar hour students have to present the paper and submit seminar material to the respective staff member, who is handling the subject. It should be preserved for 2 Semesters and produced to the flying squad and the inspection team at the time of inspection/verification.

-xXx-

**Diploma in Automobile Engineering (Full Time) (COURSE No: 1021)
M – Scheme (With effect from 2015-2016)**

List of Equivalent Subjects for L - Scheme to M – Scheme

III Semester – W.E.F OCT ‘16

Subject Code	L SCHEME	Subject Code	M SCHEME
22031	Strength of Materials	32031	Strength of Materials**
22132	Automobile Engines	32143	Automobile Engines [W.E.F AP ‘17]
22133	Automobile Chassis and Transmission	32153	Automobile Chassis and Transmission [W.E.F. OC ‘17]
22034	Machine Drawing	32033	Machine Drawing**
22035	Mechanical Testing & Quality Control Practical	32137	Strength of Materials and Metrology Practical
22136	Automobile Chassis and Transmission Practical	32156	Automobile Chassis and Transmission Practical [W.E.F. OC ‘17]
20001	Computer Application Practical	32034	Computer Applications and CAD Practical**

** Common to Diploma Mechanical Engineering

\$ Common to all Diploma Courses

IV Semester – W.E.F APR ‘17

Subject Code	L SCHEME	Subject Code	M SCHEME
22041	Manufacturing Technology – I	32032	Manufacturing Processes**
22142	Heat Power Engineering	32141	Thermal Engineering
22143	Industrial Automation	32152	Industrial Automation
22044	Computer Aided Machine Drawing Practical	32034	Computer Applications and CAD Practical**
22045	Manufacturing Technology – I Practical	32036	Lathe and Drilling Practical**
22146	Heat Power Engineering Practical	32145	Thermal Engineering and IC Engines Practical
22147	Industrial Automation Practical	32055	Process Automation Practical**

** Common to Diploma Mechanical Engineering

\$ Common to all Diploma Courses
V Semester – W.E.F OCT '17

Subject Code	L SCHEME	Subject Code	M SCHEME
22151	Industrial Management and Road Transport Organization	32151	Industrial Management and Road Transport organization
22052	Manufacturing Technology – II	32042	Special Machines**
22153	Autotronics	32144	Autotronics
22171	<u>Elective – I Theory</u> Alternate fuels and Energy systems	32172	Alternative fuels and Energy Systems
22172	Automobile Maintenance	32173	Automobile Maintenance & Emission Control
22173	Industrial Robotics	--	NO EQUIVALENT
22155	Autotronics Practical	32147	Autotronics Practical
22056	Manufacturing Technology–II Practical	32046	Special Machines Practical**
20002	Communication and Life Skills Practical	30002	Life and Employability Skills Practical \$

** Common to Diploma Mechanical Engineering
 \$ Common to all Diploma Courses

VI Semester – W.E.F APR '18

Subject Code	L SCHEME	Subject Code	M SCHEME
22161	Body Building Engineering.	32161	Automobile Body Building Engineering
22062	Computer Integrated Manufacturing	32062	Computer Aided Design and Manufacturing**
22181	<u>Elective – II Theory</u> Two and Three Wheeler Technology	32181	Two and Three Wheeler Technology
22182	Tractor and Farm Equipments	32182	Tractor and Farm Equipments
22183	Aeronautics Engineering		NO EQUIVALENT
22064	Computer Integrated Manufacturing Practical	32064	Computer Aided Design and Manufacturing Practical**
22165	Automobile Workshop Practical	32165	Automobile Workshop Practical
22184	<u>Elective - II Practical</u> Two and Three Wheeler Technology Practical	32184	<u>Elective - II Practical</u> Two and Three Wheeler Technology Practical
22185	Tractor and Farm Equipments Practical	32185	Tractor and Farm Equipments Practical
22186	Aeronautics Engineering Practical		NO EQUIVALENT
22167	Project Work	32167	Project Work \$

** Common to Diploma Mechanical Engineering

\$ Common to all Diploma Courses

ANNEXURE-I

M-SCHEME

Implemented from 2015-2016

CURRICULUM OUTLINE

1021: DIPLOMA IN AUTOMOBILE ENGINEERING (FULL TIME)

THIRD SEMESTER

Subject Code	Subject Name	HOURS PER WEEK			
		Theory	Tutorial/ Drawing	Practical	Total
32031	Strength of Materials**	6	-	-	6
32032	Manufacturing Processes**	6	-	-	6
32033	Machine Drawing**	-	4	-	4
32034	Computer Applications and CAD Practical**	-	-	6	6
32035	Foundry and Welding Practical**	-	-	4	4
32036	Lathe and Drilling Practical**	-	-	4	4
32137	Strength of Materials and Metrology Practical	-	-	4	4
	Seminar	1	-	-	1
	TOTAL	13	4	18	35

** Common with Mechanical Engineering

FOURTH SEMESTER

Subject Code	Subject Name	HOURS PER WEEK			
		Theory	Tutorial/ Drawing	Practical	Total
32141	Thermal Engineering	6	-	-	6
32042	Special Machines**	5	-	-	5
32143	Automobile Engines	6	-	-	6
32144	Autotronics	5	-	-	5
32145	Thermal Engineering and IC Engines Practical	-	-	4	4
32046	Special Machines Practical**	-	-	4	4
32147	Autotronics Practical	-	-	4	4
	Seminar	1	-	-	1
	TOTAL	23	-	12	35

** Common with Mechanical Engineering

FIFTH SEMESTER

Subject Code	Subject Name	HOURS PER WEEK			
		Theory	Tutorial/ Drawing	Practical	Total
32151	Industrial Management and Road Transport organization	6	-	-	6
32152	Industrial Automation	6	-	-	6
32153	Automobile Chassis and Transmission	5	-	-	5
ELECTIVE THEORY-I					
32071	Total Quality Management**	5	-	-	5
32172	Alternative fuels and Energy Systems				
32173	Automobile Maintenance & Emission Control				
32055	Process Automation Practical**	-	-	4	4
32156	Automobile Chassis and Transmission Practical	-	-	4	4
30002	Life and Employability Skills Practical.\$	-	-	4	4
Seminar		1	-	-	1
TOTAL		23	-	12	35

** Common with Mechanical Engineering

\$ Common to all branches

SIXTH SEMESTER

Subject Code	Subject Name	HOURS PER WEEK			
		Theory	Tutorial/ Drawing	Practical	Total
32161	Automobile Body Building Engineering	6	-	-	6
32062	Computer Aided Design and Manufacturing**	5	-	-	5
ELECTIVE THEORY-II			-	-	
32181	Two and Three Wheeler Technology	5	-	-	5
32182	Tractor and Farm Equipments				
32183	Automobile Air-Conditioning System				
32064	Computer Aided Design and Manufacturing Practical**	-	-	6	6
32165	Automobile Workshop Practical	-	-	4	4
ELECTIVE PRACTICAL					
32184	Two and Three Wheeler Technology Practical	-	-	4	4
32185	Tractor and Farm Equipments Practical				
32186	Automobile Air-Conditioning System Practical				
32167	Project Work ^{\$}	-	-	4	4
Seminar		1	-	-	1
TOTAL		17	-	18	35

** Common with Mechanical Engineering

^{\$} Common to all branches

M-SCHEME
Implemented from 2015-2016

SCHEME OF EXAMINATION

1021: DIPLOMA IN AUTOMOBILE ENGINEERING (FULL TIME)

THIRD SEMESTER

Subject Code	SUBJECT	Marks			Minimum for pass	Duration of Exam Hours
		Internal Assessment	Board Examination	Total		
32031	Strength of Materials**	25	75	100	40	3
32032	Manufacturing Processes**	25	75	100	40	3
32033	Machine Drawing**	25	75	100	40	3
32034	Computer Applications and CAD Practical**	25	75	100	50	3
32035	Foundry and Welding Practical**	25	75	100	50	3
32036	Lathe and Drilling Practical**	25	75	100	50	3
32137	Strength of Materials and Metrology Practical	25	75	100	50	3

FOURTH SEMESTER

Subject Code	SUBJECT	Marks			Minimum for pass	Duration of Exam Hours
		Internal Assessment	Board Examination	Total		
32141	Thermal Engineering	25	75	100	40	3
32042	Special Machines**	25	75	100	40	3
32143	Automobile Engines	25	75	100	40	3
32144	Autotronics	25	75	100	40	3
32145	Thermal Engineering and IC Engines Practical	25	75	100	50	3
32046	Special Machines Practical**	25	75	100	50	3
32147	Autotronics Practical	25	75	100	50	3

FIFTH SEMESTER

Subject Code	SUBJECT	Marks			Minimum for pass	Duration of Exam Hours
		Internal Assessment	Board Examination	Total		
32151	Industrial Management and Road Transport organization	25	75	100	40	3
32152	Industrial Automation	25	75	100	40	3
32153	Automobile Chassis and Transmission	25	75	100	40	3
Elective - I Theory						
32071	Total Quality Management**					
32172	Alternative fuels and Energy Systems	25	75	100	40	3
32173	Automobile Maintenance & Emission Control					
32055	Process Automation Practical**	25	75	100	50	3
32156	Automobile Chassis and Transmission Practical	25	75	100	50	3
30002	Life and Employability Skill Practical **	25	75	100	50	3

** Common to all Diploma Courses

SIXTH SEMESTER

Subject Code	SUBJECT	Marks			Minimum for pass	Duration of Exam Hours
		Internal Assessment	Board Examination	Total		
32161	Automobile Body Building Engineering	25	75	100	40	3
32062	Computer Aided Design and Manufacturing**	25	75	100	40	3
Elective - II Theory						
32181	Two and Three Wheeler Technology	25	75	100	40	3
32182	Tractor and Farm Equipments					
32183	Automobile Air-Conditioning System					
32064	Computer Aided Design and Manufacturing Practical**	25	75	100	50	3
32165	Automobile Workshop Practical	25	75	100	50	3
Elective - II Practical						
32184	Two and Three Wheeler Technology Practical	25	75	100	50	3
32185	Tractor and Farm Equipments Practical					
32186	Automobile Air-Conditioning System Practical					
32167	Project Work					

STATE BOARD OF TECHNICAL EDUCATION & TRAINING, TAMILNADU

M-SCHEME

Board Examination – Theory Paper - Question pattern

Common for all THEORY SUBJECTS except Machine Drawing

PART A - (1 to 8) 5 Questions are to be answered out of 8 questions for 2 marks each. (Question No. 8 will be the compulsory question and can be asked from any one of the units) (From each unit maximum of two 2 marks questions alone can be asked)

PART B - (9 to 16) 5 Questions are to be answered out of 8 questions for 3 marks each. (Question No. 16 will be the compulsory question and can be asked from any one of the units) (From each unit maximum of two 3 marks questions alone can be asked)

PART C - (17 to 21) Five Questions will be in the Either OR Pattern. Students have to answer these five questions. Each question carries 10 marks. (Based on the discretion of the question setter, he/she can ask two five mark questions (with sub division A & sub division B) instead of one ten marks question if required)

Any tables or data required should be mentioned in the question pattern/paper. Steam table, Design Data Book, Mollier chart, Psychometric Chart etc..

PRACTICAL SUBJECTES

Question Pattern for Practical Examinations will vary according to respective practical



DIRECTORATE OF TECHNICAL EDUCATION

DIPLOMA IN AUTOMOBILE ENGINEERING

M SCHEME

2015 -2016 onwards

II YEAR

III SEMESTER

32031 – STRENGTH OF MATERIALS

CURRICULUM DEVELOPMENT CENTRE

STATE BOARD OF TECHNICAL EDUCATION & TRAINING, TAMILNADU

M-SCHEME

(Implemented for the students Admitted from the Year 2015-2016 on wards)

Course Name : DIPLOMA IN AUTOMOBILE ENGINEERING
Course Code : 1021
Subject Code : 32031
Semester : III
Subject Title : **STRENGTH OF MATERIALS**

TEACHING AND SCHEME OF EXAMINATIONS:

No. of Weeks per Semester: 15 Weeks

Subject	Instructions		Examination			Duration
	Hours / Week	Hours / Semester	Marks			
Strength of Materials	6	90	Internal Assessment	Board Examination	Total	3 Hrs
			25	75	100	

Topics and Allocation of Hours:

Unit No	Topics	Hours
I	STATICS OF PARTICLE AND FRICTION	17
II	MECHANICAL PROPERTIES, SIMPLE STRESSES AND STRAINS	17
III	GEOMETRICAL PROPERTIES OF SECTIONS AND THIN SHELLS	17
IV	SHEAR FORCE AND BENDING MOMENT DIAGRAMS, THEORY OF SIMPLE BENDING	16
V	TORSION AND SPRINGS	16
	TEST AND REVISION	7
	Total	90

RATIONALE:

Day by day, engineering and technology experience tremendous growth. Design plays a major role in developing engineering and technology. Strength of material is backbone for design. The strength of material deals generally with the behaviour of objects, when they are subject to actions of forces. Evaluations derived from these basic fields provide the tools for investigation of mechanical structure.

OBJECTIVES

- Define various Support reaction and equilibrium.
- Calculate the deformation of materials, which are subjected to axial load and shear.
- Determine the moment of Inertia of various sections used in industries.
- Estimate the stresses induced in thin shells.
- Draw the shear force and bending moment diagram of the beam for different loads.

32031-STRENGTH OF MATERIALS

DETAILED SYLLABUS

Contents: Theory

Unit	Name of the Topic	Hours
I	STATICS OF PARTICLES: Introduction – Force - effects of a force - system of forces - resultant of force - Principle of transmissibility - parallelogram law of forces - triangular law - resultant of several forces acting on a particle - polygon law - resolution of a force into rectangular components – resultant of a system of forces acting on a particle using rectangular components - equilibrium of particles. External and internal forces - moment of a force - Varignon's theorem - moment of a couple - equivalent couples - addition of couples - resolution of a force into a force and a couple - Free body diagram - Necessary and sufficient conditions for the equilibrium of rigid bodies in two dimension - Support reaction - types of support - removal of two dimensional supports - Simple problems only.	17

	<p>FRICITION:</p> <p>Introduction - Definition - Force of friction - Limiting friction - Static friction - Dynamic friction - Angle of friction - co-efficient of friction - Laws of static and dynamic friction.</p>	
II	<p>DEFORMATION OF METALS</p> <p>Mechanical properties of materials: Engineering materials – Ferrous and non-ferrous materials - Definition of mechanical properties - Alloying elements-effect of alloying element - Fatigue, fatigue strength, creep – temperature creep – cyclic loading and repeated loading – endurance limit.</p> <p>Simple stresses and strains: Definition – Load, stress and strain – Classification of force systems – tensile, compressive and shear force systems – Behaviour of mild steel in tension up to rupture – Stress – Strain diagram – limit of proportionality – elastic limit – yield stress – breaking stress – Ultimate stress – percentage of elongation and percentage reduction in area – Hooke’s law – Definition – Young’s modulus - working stress, factor of safety, load factor, shear stress and shear strain - modulus of rigidity. Linear strain – Deformation due to tension and compressive force – Simple problems in tension, compression and shear force.</p> <p>Definition – Lateral strain – Poisson’s ratio – volumetric strain – bulk modulus – volumetric strain of rectangular and circular bars – problems connecting linear, lateral and volumetric deformation – Elastic constants and their relationship - Problems on elastic constants - Definition – Composite bar – Problem in composite bars subjected to tension and compression – Temperature stresses and strains – Simple problems – Definition – strain energy – proof resilience – modulus of resilience – The expression for strain energy stored in a bar due to Axial load – Instantaneous stresses due to gradual, sudden, impact and shock loads – Problems computing instantaneous stress and deformation in gradual, sudden, impact and shock loadings.</p>	17

III	<p>GEOMETRICAL PROPERTIES OF SECTIONS AND THIN SHELLS</p> <p>Properties of sections: Definition – center of gravity and centroid - position of centroids of plane geometrical figures such as rectangle, triangle, circle and trapezium-problems to determine the centroid of angle, channel, T and I sections only - Definition-centroidal axis-Axis of symmetry. Moment of Inertia – Statement of parallel axis theorem and perpendicular axis theorem. Moment of Inertia of lamina of rectangle, circle, triangle, I and channel sections-Definition-Polar moment of Inertia-radius of gyration – Problems computing moment of inertia and radius of gyration for angle, T, Channel and I sections.</p> <p>Thin Shells: Definition – Thin and thick cylindrical shell – Failure of thin cylindrical shell subjected to internal pressure – Derivation of Hoop and longitudinal stress causes in a thin cylindrical shell subjected to internal pressure – simple problems – change in dimensions of a thin cylindrical shell subjected to internal pressure – problems – Derivation of tensile stress induced in a thin spherical shell subjected to internal pressure – simple problems – change in diameter and volume of a thin spherical shell due to internal pressure – problems.</p>	17
IV	<p>SF AND BM DIAGRAMS OF BEAMS AND THEORY OF BENDING</p> <p>Classification of beams – Definition – shear force and Bending moment – sign conventions for shear force and bending moment – types of loadings – Relationship between load, force and bending moment at a section – shear force diagram and bending moment diagram of cantilever and simply supported beam subjected to point load and uniformly distributed load (udl) – Determination of Maximum bending moment in cantilever beam and simply supported beam when they are subjected to point load and uniformly distributed load.</p> <p>Theory of simple bending – Assumptions – Neutral axis – bending stress distribution – moment of resistance – bending equation – $M/I=f/y=E/R$ – Definition – section modulus - rectangular and circular sections – strength of beam – simple problems involving flexural</p>	16

	formula for cantilever and simple supported beam.	
V	<p>THEORY OF TORSION AND SPRINGS</p> <p>Theory of torsion – Assumptions – torsion equation $\frac{T}{J} = \frac{f_s}{R} = \frac{C\theta}{l}$ – strength of solid and hollow shafts – power transmitted – Definition – Polar modulus – Torsional rigidity – strength and stiffness of shafts – comparison of hollow and solid shafts in weight and strength considerations – Advantages of hollow shafts over solid shafts – Problems.</p> <p>Types of springs – Laminated and coiled springs and applications – Types of coiled springs – Difference between open and closely coiled helical springs – closely coiled helical spring subjected to an axial load – problems to determine shear stress, deflection, stiffness and resilience of closed coiled helical springs</p>	16

Text Books:

- 1) Strength of Materials, R. S. Khurmi, S.Chand & Co., Ram Nagar, New Delhi.
- 2) Strength of Materials, S. Ramamrutham, 15th Edn 2004, DhanpatRai Pub. Co., New Delhi.

Reference Books:

- 1) Strength of Materials, R.K. Bansal,, Laxmi Publications Pvt. Ltd., New Delhi, 3rd Edition, 2010.
- 2) Strength of materials, S.S.Rattan, Tata Mcgraw hill, New Delhi,2008, ISBN 9780070668959,
- 3) Strength of Materials, B K Sarkar, I Edition, 2003 Tata Mcgraw hill, New Delhi.
- 4) Engineering mechanics, R.K. Bansal, Laxmi Publications Pvt. Ltd., New Delhi, 2nd Edition, 2007



DIRECTORATE OF TECHNICAL EDUCATION

DIPLOMA IN AUTOMOBILE ENGINEERING

M SCHEME

2015 -2016 onwards

II YEAR

III SEMESTER

32032 – MANUFACTURING PROCESSES

CURRICULUM DEVELOPMENT CENTRE

STATE BOARD OF TECHNICAL EDUCATION & TRAINING, TAMILNADU

M-SCHEME

(Implemented for the students Admitted from the Year 2015-2016 on wards)

Course Name : DIPLOMA IN AUTOMOBILE ENGINEERING
Course Code : 1021
Subject Code : 32032
Semester : III
Subject Title : **MANUFACTURING PROCESSES**

TEACHING AND SCHEME OF EXAMINATIONS:

No. of weeks per semester: 15 Weeks

Subject	Instructions		Examination			
	Hours / Week	Hours / Semester	Marks			Duration
Manufacturing Processes	6	90	Internal Assessment	Board Examination	Total	3 Hrs
			25	75	100	

Topics and Allocation of Hours:

Unit No	Topics	Hours
I	FOUNDRY TECHNOLOGY	17
II	WELDING TECHNOLOGY	17
III	FORMING TECHNOLOGY	17
IV	THEORY OF METAL CUTTING & LATHE	16
V	DRILLING & METROLOGY	16
	TEST AND REVISION	7
	TOTAL	90

RATIONALE:

Manufacturing, the major and the most important aspect in industries needs utmost care and attention. Knowledge about various processes and allied areas will

be of great use to the personnel involved in production. This will provide the students an opportunity to skill themselves for the industrial scenario.

OBJECTIVES:

- Acquire Knowledge about types of pattern, casting, and moulding.
- Describe the various casting processes.
- Knowledge about various welding process and its working principle.
- Appreciate the safety practices used in welding.
- Acquire knowledge about various forming technologies.
- Knowledge about the lathe and its working parts.
- Describe the functioning of semi-automatic lathes.
- Study about the drilling process.
- Study about metrology and measuring instruments.

**32032 - MANUFACTURING PROCESSES
DETAILED SYLLABUS**

Contents: Theory

Unit	Name of the Topic	Hours
I	<p>Foundry Technology</p> <p>Patterns: Definition – types of pattern – solid piece – split piece - loose piece – match plate - sweep - skeleton – segmental – shell – pattern materials – pattern allowances.</p> <p>Moulding: Moulding sand – constituents – types – properties of moulding sand – moulding sand preparation – moulding tools - moulding boxes – types of moulds – green sand mould – dry sand mould – loam mould – methods of moulding – moulding machines – jolting – squeezing – sand slinger construction and working principle.</p> <p>Cores: Essential qualities of core – materials – core sand preparation – core binders – core boxes - CO₂ process core making – types of core.</p> <p>Metallurgy :- Introduction - Iron-carbon diagram.</p> <p>Melting furnaces: Blast furnace – Cupola furnace – crucible furnace – types – pit furnace – coke fired – oil fired – electric</p>	17

	<p>furnace – types – direct arc – indirect arc – induction furnace – working principles.</p> <p>Casting: Shell mould casting – investment casting – pressure die casting – hot chamber die casting – cold chamber die casting – gravity die casting – centrifugal casting – continuous casting - defects in casting – causes and remedies.</p>	
II	<p>Welding Technology</p> <p>Arc Welding: Definition – arc welding equipment – electrode types – filler and flux materials - arc welding methods – metal arc - Metal Inert gas (MIG) - Tungsten inert gas (TIG) - Submerged arc - Electro slag welding – resistance welding – spot welding – butt welding – seam welding – Plasma arc welding – Thermit welding – Electron beam welding – Laser beam welding – friction welding – ultrasonic welding – Induction welding - working principle – applications – advantages and disadvantages.</p> <p>Gas welding: Oxy-acetylene welding – advantages - limitations - gas welding equipment - Three types of flames – welding techniques – filler rods. – Flame cutting – soldering – brazing – difference between soldering and brazing.</p> <p>Types of welded joints – merits and demerits of welded joints – inspection and testing of welded joints – destructive and non-destructive types of tests – magnetic particle test – radiographic and ultrasonic test - defects in welding – causes and remedies.</p>	17
III	<p>Forming Technology</p> <p>Forging: Hot working, cold working – advantages of hot working and cold working– hot working operations – rolling, forging, smith forging, drop forging, upset forging, press forging – roll forging.</p> <p>Press Working: Types of presses - mechanical and hydraulic presses - press tools and accessories - press working operations - bending operations - angle bending - channel bending – curling – drawing - shearing operations - blanking, piercing, trimming – notching – lancing.</p> <p>Powder Metallurgy: Methods of manufacturing metal powders –</p>	17

	atomization, reduction and electrolysis deposition – compacting – sintering – sizing – infiltration – mechanical properties of parts made by powder metallurgy – design rules for the powder metallurgy process.	
IV	<p>Theory of metal cutting: Introduction – orthogonal cutting – oblique cutting - single point cutting tool – nomenclature – types of chips – chip breakers – cutting tool materials – properties – tool wears – factors affecting tool life – cutting fluids – functions – properties of cutting fluid.</p> <p>Centre Lathe: Introduction - specifications – simple sketch – principal parts – head stock – back geared type – all geared type – feed mechanism - tumbler gear mechanism – quick change gear box – apron mechanism – work holding device – three jaw chuck – four jaw chuck – centres - faceplate – mandrel – steady rest – follower rest – machining operations done on lathe - straight turning – step turning - taper turning methods: form tool – tailstock set over method – compound rest method – taper turning attachment – knurling - Thread cutting – Facing – Boring – chamfering –grooving – parting-off – eccentric turning - cutting speed – feed - depth of cut - metal removal rate.</p> <p>Semi-Automatic Lathes: Types of semi-automatic lathes – capstan and turret lathes – Geneva indexing mechanism – bar feeding mechanism - difference between turret and capstan – work holding devices – tool holders.</p>	16
V	<p>Drilling and Metrology</p> <p>Drilling Machines: Drills - flat drills - twist drills – nomenclature of twist drill - types of drilling machines - bench type - floor type - radial type - gang drill – multi spindle type -principle of operation in drilling - methods of holding drill bit - drill chucks - socket and sleeve –drilling operation – reaming - counter sinking - counter boring - spot facing – tapping - deep hole drilling.</p> <p>Metrology: Definition – need of inspection – precision – accuracy – sensitivity - magnification – repeatability – calibration –</p>	16

	<p>comparator – Advantages – requirements – mechanical comparator – optical comparator – electrical comparator – pneumatic comparator – Principles – advantages and disadvantages.</p> <p>Measuring instruments: Construction and principles only - Steel rule – Callipers: outside calliper – inside calliper – jenny calliper – Combination set – Feeler gauge – Pitch screw gauge – Vernier calliper – Digital calliper – Vernier height gauge – Micrometer – Inside micrometer – Thread micrometer – Slip gauges – requirement – Indian standard – care and use - Sine bar – types – uses – limitations – Working principle of clinometers, autocollimator, angle dekkor.</p>	
--	--	--

Text Books:

- 1) Elements of workshop Technology Volume I & II – Hajra Chowdry & Bhattacharaya - IIth Edition - Media Promoters & Publishers Pvt. Ltd., Seewai Building `B`, 20-G, Noshir Bharucha Marg, Mumbai 400 007 – 2007.
- 2) Introduction of basic manufacturing processes and workshop technology – Rajendersingh – New age International (P) Ltd. Publishers, 4835/24, Ansari Road, Daryaganj, New Delhi - 110002

Reference Books:

- 1) Manufacturing process – Begeman - 5th Edition -McGraw Hill, New Delhi 1981.
- 2) Workshop Technology- WAJ Chapman - Volume I, II, & III – Vima Books Pvt. Ltd., 4262/3, Ansari Road, Daryaganj, New Delhi 110 002.
- 3) Workshop Technology – Raghuwanshi - Khanna Publishers. Jain & Gupta,
- 4) Production Technology, Edn. XII, Khanna Publishers, 2-B, North Market, NAI Sarak, New Delhi 110 006 - 2006
- 5) Production Technology - P. C. SHARMA - Edn. X - S.Chand & Co. Ltd., Ram Nagar, New Delhi 110 055 - 2006
- 6) Production Technology – HMT - Edn. 18 - published by Tata McGraw Hill publishing Co. Ltd., 7 West Patel nagar, New Delhi 110 008. – 2001.



DIRECTORATE OF TECHNICAL EDUCATION
DIPLOMA IN AUTOMOBILE ENGINEERING

M SCHEME

2015 -2016 onwards

II YEAR

III SEMESTER

32033 – MACHINE DRAWING

CURRICULUM DEVELOPMENT CENTRE

STATE BOARD OF TECHNICAL EDUCATION & TRAINING, TAMILNADU

M-SCHEME

(Implemented for the students Admitted from the Year 2015-2016 on wards)

Course Name : DIPLOMA IN AUTOMOBILE ENGINEERING
Course Code : 1021
Subject Code : 32033
Semester : III
Subject Title : **MACHINE DRAWING**

TEACHING AND SCHEME OF EXAMINATIONS:

No. of Weeks per Semester: 15 Weeks

Subject	Instructions		Examination			Duration
	Hours /Week	Hours/ Semester	Marks			
Machine Drawing	4	60	Internal Assessment	Board Examination	Total	3 Hrs
			25	75	100	

Topics and Allocation of Hours:

Unit	Topics	Hours
I	Sectional Views	5
II	Limits, Fits and Tolerances	5
III	Surface Texture	5
IV	Keys, Screw threads and Threaded fasteners	5
V	Assemble drawing	33
	TEST AND REVISION	7
	Total	60

RATIONALE:

Manufacturing of various parts start from the basic drawing of components. The assembly of components is also carried out from the drawing. So drawing is an

important subject to be studied by the students to carry and complete the production and assembly process successfully.

OBJECTIVES:

- Appreciate the need for sectional view and types of sections.
- Draw sectional views using different types of sections.
- Explain the use of threaded fasteners and the types of threads.
- Compare hole basis system with shaft basis system.
- Select different types of fits and tolerance for various types of mating parts.
- Appreciate the importance of fits and tolerance.

**32033 - MACHINE DRAWING
DETAILED SYLLABUS**

Contents: Theory

Unit	Name of the Topic	Hours
I	SECTIONAL VIEWS Review of sectioning – Conventions showing the section – symbolic representation of cutting plane- types of section – full section, half section, offset section, revolved section, broken section, removed section – section lining.	5
II	LIMITS, FITS AND TOLERANCES Tolerances – Allowances – Unilateral and Bilateral tolerances. Limits – Methods of tolerances – Indication of tolerances on linear dimension of drawings – Geometrical tolerances – application – Fits – Classifications of fits – Selection of fits – examples	5
III	SURFACE TEXTURE Surface texture – importance – controlled and uncontrolled surfaces – Roughness – Waviness – lay – Machining symbols	5
IV	KEYS, SCREW THREADS AND THREADED FASTENERS Types of fasteners – temporary fasteners – keys – classification of keys – Heavy duty keys – light duty keys. Screw thread – Nomenclature – different types of thread profiles – threads in sections – threaded fasteners – bolts – nuts – through bolt – tap bolt, stud bolt	5

	– set screw – cap screws – machine screws – foundation bolts	
V	<p>MANUAL DRAWING PRACTICE</p> <p>Detailed drawings of following machine parts are given to students to assemble and draw the Elevations / Sectional elevations / Plan / and Side views with dimensioning and bill of materials</p> <ol style="list-style-type: none"> 1. Sleeve & Cotter joint 2. Knuckle joint 3. Screw Jack 4. Foot step bearing 5. Plummer Block 6. Universal Coupling 7. Simple Eccentric 8. Machine Vice 9. Protected type flanged coupling 10. Swivel bearing. 	33

Books:

- 1) Machine Drawing, P.S. Gill, Katsan Publishing House, Ludiana
- 2) A Text book of Engineering Drawing, R.B. Gupta, Satya Prakashan, Technical India Publications, New Delhi
- 3) Mechanical Draughtsmanship, G.L. Tamta, Dhanpat Rai & Sons, Delhi
- 4) Geometrical and Machine Drawing, N.D. Bhatt, Cheroter book stalls, Anand, West Railway
- 5) Engineering Drawing, D.N. Ghose, Dhanpat Rai & Sons, Delhi

BOARD EXAMINATIONS

Question Pattern

Time: 3 Hrs

Max Marks : 75

Note: All the questions will be answered in drawing sheet only

PART A: (7 x 5 = 35)

Theory questions: (1 TO 8)

Two questions from each unit (I to IV) will be asked.

Answer any seven questions from the given eight questions.

PART B: 40 Marks (Either A or B.)

Answer any one question by selecting either A or B.

9. A. Assemble and Draw any two views and bill of materials.

(OR)

B. Assemble and Draw any two views and bill of material



DIRECTORATE OF TECHNICAL EDUCATION

DIPLOMA IN AUTOMOBILE ENGINEERING

M SCHEME

2015 -2016 onwards

II YEAR

III SEMESTER

**32034 – COMPUTER APPLICATIONS AND
CAD PRACTICAL**

CURRICULUM DEVELOPMENT CENTRE

STATE BOARD OF TECHNICAL EDUCATION & TRAINING, TAMILNADU

M-SCHEME

(Implemented for the students Admitted from the Year 2015-2016 on wards)

Course Name : DIPLOMA IN AUTOMOBILE ENGINEERING
Course Code : 1021
Subject Code : 32034
Semester : III
Subject Title : COMPUTER APPLICATIONS AND CAD PRACTICAL

TEACHING AND SCHEME OF EXAMINATIONS:

No. of weeks per semester: 15 Weeks

Subject	Instructions		Examination			Duration
	Hours / Week	Hours / Semester	Marks			
Computer Applications and CAD practical	6	90	Internal Assessment	Board Examination	Total	3 Hrs
			25	75	100	

OBJECTIVES:

On completion of the exercises, the students must be able to

- Use the different facilities available in the word processor
- Analyze the data sheet
- Create and manipulate the database
- Prepare PowerPoint presentation
- Practice on CADD commands in making 2D Drawings.
- Draw assembled drawings using CADD.
- Draw sectional views using different types of sections.

PART – A: COMPUTER APPLICATIONS (30 Hrs)

WORD PROCESSING

Introduction – Menus – Tool bar – Create – Edit – Save – Alignment – Font Size – Formatting – Tables – Fill Colors – Page Setup - Preview – Water marking – Header – Footer – Clip art.

Exercises

1. Create a news letter of three pages with two columns text. The first page contains some formatting bullets and numbers. Set the document background colour and add 'confidential' as the watermark. Give the document a title which should be displayed in the header. The header/ footer of the first page should be different from other two pages. Also, add author name and date/ time in the header. The footer should have the page number.

2. Create the following table using align, border, merging and other attributes.

<u>DIRECTORATE OF TECHNICAL EDUCATION</u>					
e-governance particulars					
Register Number	June	July	August	September	Cumulative %
16304501					
16304502					
16304503					
16304504					
16304505					

SPREADSHEET

Introduction – Menus – Tool bar – Create – Edit – Save – Formatting cells – Chart wizard – Fill Colors – Creating and using formulas – Sorting – Filtering.

Exercises

3. Create a table of records with columns as Name and Donation Amount. Donation amount should be formatted with two decimal places. There should be at least twenty records in the table. Create a conditional format to highlight the highest donation with blue colour and lowest donation with red colour. The table should have a heading.

4. Prepare line, bar and pie chart to illustrate the subject wise performance of the class for any one semester.

DATABASE

Introduction – Menus – Tool bar – Create – Edit – Save – Data types – Insert – Delete – Update – View – Sorting and filtering – Queries – Report – Page setup – Print.

Exercises

5. Prepare a payroll for employee database of an organization with the following details: Employee Id, Employee name, Date of Birth, Department and Designation, Date of appointment, Basic pay, Dearness Allowance, House Rent Allowance and other deductions if any. Perform simple queries for different categories.

6. Design a pay slip for a particular employee from the above database.

PRESENTATION

Introduction – Menus – Tool bar – Create – Edit – Save – Slide transition – Insert image – Hyper link – Slide numbers – View slide show with sound – Photo album – Clip art.

Exercises

7. Make a presentation with atleast 10 slides. Use different customized animation effects on pictures and clip art on any four of the ten slides.

PART – B: CAD (60 Hrs)

INTRODUCTION

Introduction – History of CAD – Applications – Advantages over manual drafting – Hardware requirements – Software requirements – Windows desktop – CAD screen interface – menus – Tool bars – How to start CAD – How to execute command – types of co-ordinate systems – Absolute – Relative – Polar.

DRAWING AIDS AND EDITING COMMANDS

Creating objects (2D) – Using draw commands – Creating text – Drawing with precision – Osnap options – drafting settings – drawing aids – Fill, Snap, Grid, Ortho lines – Function keys - Editing and modify commands – Object selection methods – Erasing object – Oops - Cancelling and undoing a command – Copy – Move – Array

– Offset – Scale – Rotate – Mirror – Break – Trim – Extend – Explode. Divide – Measure – stretch – Lengthen – Changing properties – Color – line types –LT scale – Matching properties – Editing with grips – Pedit – Ddedit – Mledit.

BASIC DIMENSIONING, HATCHING, BLOCKS AND VIEWS

Basic dimensioning – Editing dimensions – Dimension styles – Dimension system variables. Machine drawing with CAD. Creation of blocks – Wblock – inserting a block – Block attributes – Hatching –Pattern types – Boundary hatch – working with layers - Controlling the drawing display – Blipmode – View group commands – Zoom, redraw, regen, regenauto, pan, viewres – Real time zoom. Inquiry groups – calculating area – Distance – Time – Status of drawing – Using calculator.

CAD EXERCISES

Detailed drawings of following machine parts are to be given to students. Draw the assembled views (two views only) and bill of materials.

The elevation / sectional elevation / plan / sectional plan / side view with dimensioning.

1. Sleeve & Cotter joint
2. Screw jack
3. Plummer Block
4. Simple Eccentric
5. Machine Vice
6. Protected type flanged coupling

Reference Books:

- 1) Inside AutoCAD - D. Raker and H. Rice - BPB Publications, NewDelhi
- 2) Engineering Drawing and Graphics + AutoCAD – K.Venugopal, - New Age International Publications
- 3) AutoCAD with Applications - Sham Tickoo - Tata Mcgraw Hill.

Board of Examination

Note: All the exercises have to be completed. Two exercises will be given for examination by selecting one exercise in each PART.

All the exercises should be given in the question paper and students are allowed to select by a lot.

Record note book should be submitted during examination.

ALLOCATION OF MARKS

PART - A		:	25 marks
Editing / Creation	-	10	
Formatting	-	10	
Printout	-	5	
PART - B		:	45 marks
Drafting	-	20	
Assembly	-	10	
Dimensioning	-	10	
Printout	-	5	
Viva-voce		:	05 marks
Total		:	75 marks

LIST OF EQUIPMENT

1. Personal computer – 30 Nos.
2. Printer – 1 No.
3. Required Softwares :

Office Package, CAD Package – Sufficient to the strength.



DIRECTORATE OF TECHNICAL EDUCATION
DIPLOMA IN AUTOMOBILE ENGINEERING

M SCHEME
2015 -2016 onwards

II YEAR
III SEMESTER

32035 – FOUNDRY AND WELDING PRACTICAL

CURRICULUM DEVELOPMENT CENTRE

STATE BOARD OF TECHNICAL EDUCATION & TRAINING, TAMILNADU

M-SCHEME

(Implemented for the students Admitted from the Year 2015-2016 on wards)

Course Name : DIPLOMA IN AUTOMOBILE ENGINEERING
Course Code : 1021
Subject Code : 32035
Semester : III
Subject Title : FOUNDRY AND WELDING PRACTICAL

TEACHING AND SCHEME OF EXAMINATIONS:

No. of weeks per semester: 15 Weeks

Subject	Instructions		Examination			Duration
	Hours/ Week	Hours/ Semester	Marks			
Foundry and Welding Practical	4	60	Internal	Board	Total	3 Hrs
			Assessment	Examination		
			25	75	100	

OBJECTIVES:

- Identify the tools used in foundry.
- Identify the tools and equipment used in welding
- Prepare sand moulds for different patterns.
- Perform welding operation to make different types of joints.
- Identify the different welding defects.
- Appreciate the safety practices used in welding.
- Prepare a record of work for all the exercises.

Foundry Section

1. Introduction of tools and equipment
2. Types of patterns
3. Types of sand
4. Preparation of sand moulds
5. Core sands, preparation of cores

Exercises:

Prepare the green sand mould using the following patterns.

Solid pattern

1. Stepped pulley

Split pattern

2. Bent Pipe with core print
3. T-pipes with core print
4. Tumbles

Loose Piece Pattern

5. Dovetail

Core preparation

6. Core preparation for Bent pipe / T-pipe

Welding Section

1. Introduction of Safety in welding shop
2. Introduction to hand tools and equipment
3. Arc and gas welding equipment
4. Types of joints

Exercises :

Make the following welding joint / cutting.

Arc welding (Raw Material: 25 mm x 6mm MS flat)

1. Lap joint
2. Butt joint
3. T- joint

Gas Welding (Raw Material: 25mm x 3mm Ms flat)

4. Lap joint

Gas cutting: (GI/MS Sheet - 3mm thickness)

5. Profile cutting – circular profile

Spot welding: (GI/MS Sheet)

6. Lap joint

BOARD EXAMINATION

Note: All the exercises in both sections have to be completed. Two exercises will be given for examination by selecting one exercise in each section.

All the exercises should be given in the question paper and students are allowed to select by a lot.

Record note book should be submitted during examination.

Detailed allocation

Foundry		: 35 marks
Preparation of sand	- 10	
Ramming and vent holes	- 15	
Gate cutting / Finish	- 10	
Welding		: 35 marks
Edge preparation	- 10	
Welding / Cutting	- 15	
Joint strength / Finish	- 10	
Viva-voce		: 05 marks
Total		: 75 marks

LIST OF EQUIPMENT

Welding:

1. Arc welding booth	-	2 No's with welding transformer
2. Gas welding unit	-	1 Set (Oxygen and acetylene cylinder)
3. Flux	-	Sufficient quantity
4. Electrode	-	Sufficient quantity
5. Welding rod	-	Sufficient quantity
6. Welding shield	-	5 Nos.
7. Gas welding goggles	-	5 Nos.
8. Leather Glows 18"	-	10 Sets.
9. Chipping hammer	-	10 Nos.
10. Spot welding machine	-	1 No.
11. Personal protective equipment	-	Sufficient quantity
12. Fire safety equipment	-	Sufficient quantity

Foundry:

1. Moulding board	-	15 Nos.
2. Cope box	-	15 Nos.
3. Drag box	-	15 Nos.
4. Core box	-	10 Nos.
5. Shovel	-	5 Nos.
6. Rammer set	-	15 Nos.
7. Slick	-	15 Nos.
8. Strike-off bar	-	15 Nos.
9. Riddle	-	5 Nos.
10. Trowel	-	15 Nos.
11. Lifter	-	15 Nos.
12. Cleaning Brush	-	20 Nos.
13. Vent rod	-	15 Nos.
14. Draw spike	-	15 Nos.
15. Gate cutter	-	15 Nos.
16. Runner & riser	-	15 Nos. each
17. Patterns	-	Sufficient quantity



DIRECTORATE OF TECHNICAL EDUCATION
DIPLOMA IN AUTOMOBILE ENGINEERING

M SCHEME

2015 -2016 onwards

II YEAR

III SEMESTER

32036 – LATHE AND DRILLING PRACTICAL

CURRICULUM DEVELOPMENT CENTRE

STATE BOARD OF TECHNICAL EDUCATION & TRAINING, TAMILNADU

M-SCHEME

(Implemented for the students Admitted from the Year 2015-2016 on wards)

Course Name : DIPLOMA IN AUTOMOBILE ENGINEERING
Course Code : 1021
Subject Code : 32036
Semester : III
Subject Title : LATHE AND DRILLING PRACTICAL

TEACHING AND SCHEME OF EXAMINATIONS:

No. of weeks per semester: 15 Weeks

Subject	Instructions		Examination			Duration
	Hours/ Week	Hours/ Semester	Marks			
Lathe and Drilling Practical	4	60	Internal	Board	Total	3 Hrs
			Assessment	Examination		
			25	75	100	

OBJECTIVES:

- Identify the parts of a lathe.
- Identify the work holding devices.
- Set the tools for various operations.
- Operate the lathe and machine a component using lathe.
- Identify the parts of drilling machine.
- Perform the various drilling operations.
- Identify the various tools and its holding devices.
- Identify the work holding devices.
- Prepare the record of work for the exercises.

Lathe section:

1. Introduction of safety in operating machines.
2. Study of lathe and its parts.
3. Types of tools used in lathe work.

4. Study of work holding devices and tool holding devices.
5. Setting of work and tools.
6. Operation of lathe.
7. Practice on a lathe.
8. Types of measuring instruments and their uses.

Exercises:

Make the following jobs in the lathe. Raw material \square 32 mm M.S. Rod

1. Facing, Step turning & Chamfering

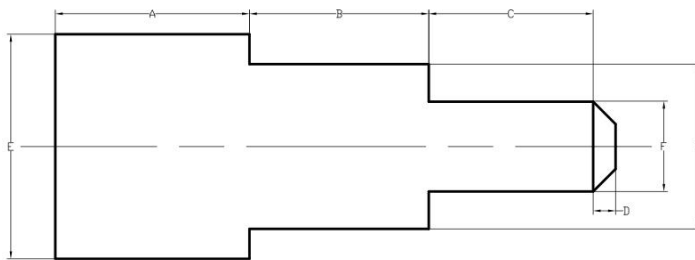

Dimensions			
Sl.No	Part Name	Actual	Obtained

2. Step turning & Groove cutting

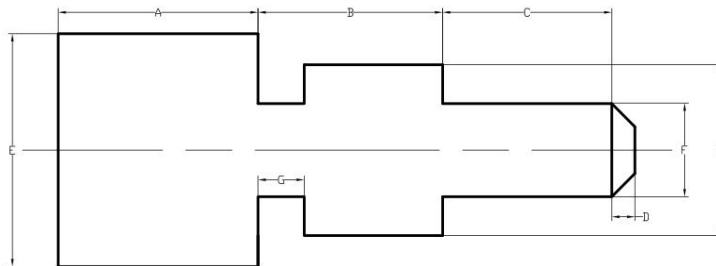

Dimensions			
Sl.No	Part Name	Actual	Obtained

3. Step turning & Taper turning

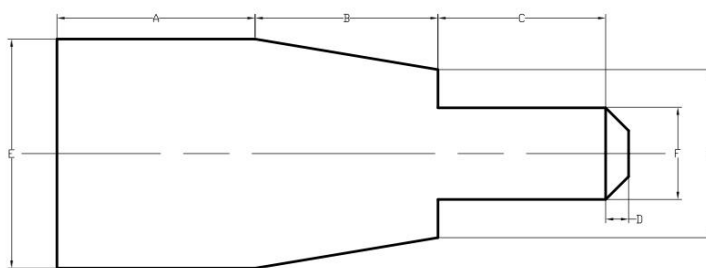

Dimensions			
Sl.No	Part Name	Actual	Obtained

4. Step turning & Knurling

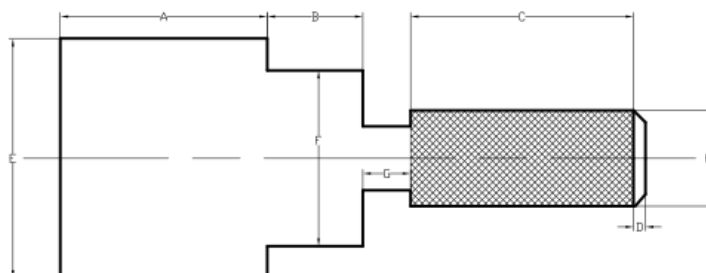

Dimensions			
Sl.No	Part Name	Actual	Obtained

5. Step turning & Thread cutting (L.H.)

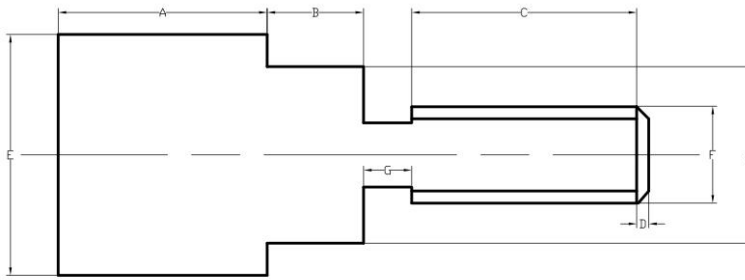

Dimensions			
Sl.No	Part Name	Actual	Obtained

6. Step turning & Thread cutting (R.H.)

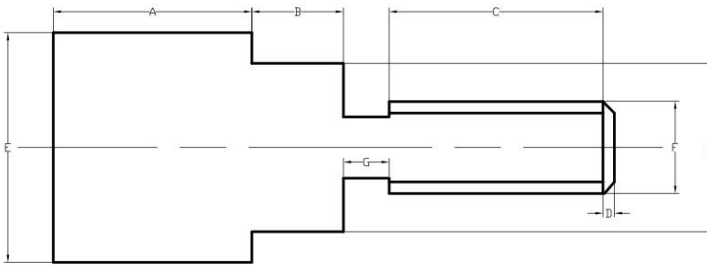

Dimensions			
Sl.No	Part Name	Actual	Obtained

7. Bush: Turning & Drilling

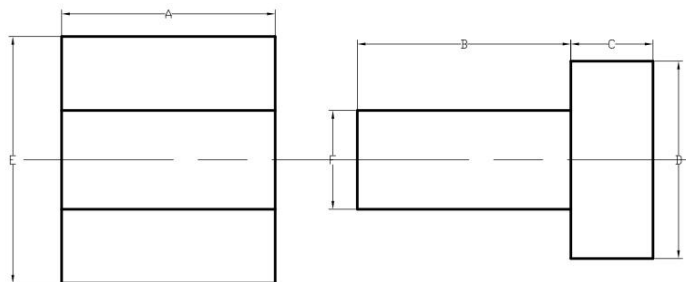

Dimensions			
Sl.No	Part Name	Actual	Obtained

8. Eccentric turning

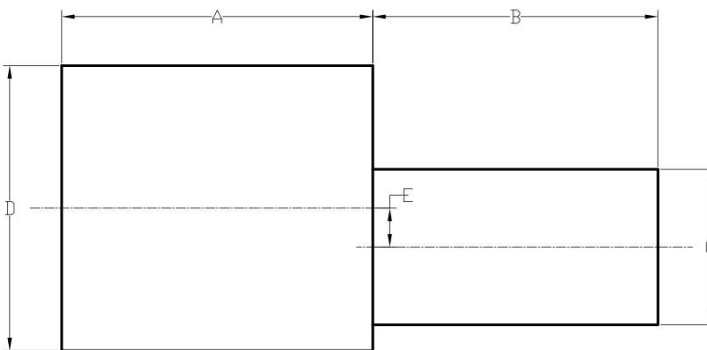

Dimensions			
Sl.No	Part Name	Actual	Obtained

Drilling section:

1. Introduction of safety in operating machines.
2. Study of drilling machines and its parts.
3. Study the types of tools used.
4. Study of work holding devices and tool holding devices.
5. Setting of work and tools.
6. Operation and practice.
7. Types of measuring instruments and their uses.

Exercises:

Make the following jobs in the drilling machine.

Raw material 50mm X 50mm X 20 mm thick M.S. Flat

1. Drilling & Tapping

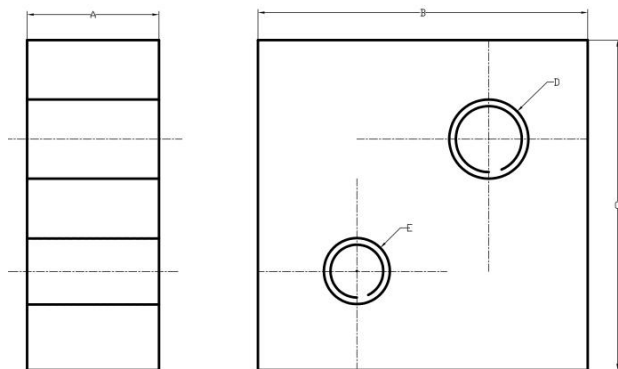

Dimensions			
Sl.No	Part Name	Actual	Obtained

2. Drilling & Counter boring

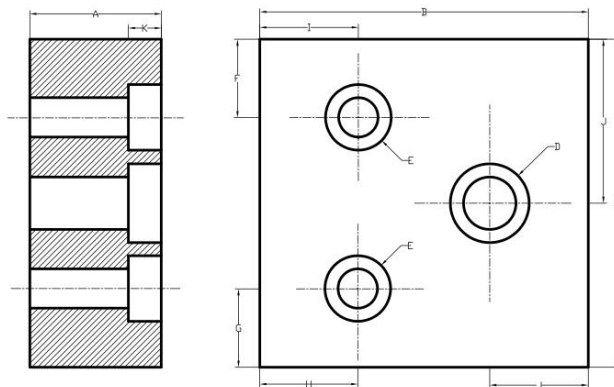

Dimensions			
Sl.No	Part Name	Actual	Obtained

3. Drilling & Counter sinking

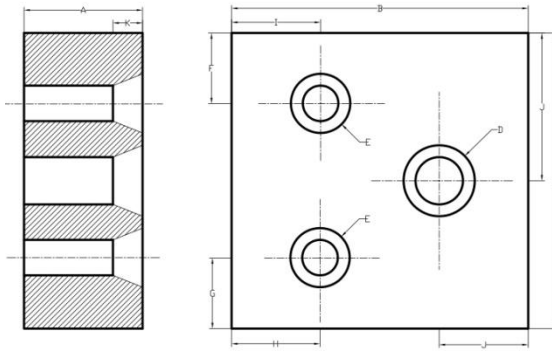

Dimensions			
Sl.No	Part Name	Actual	Obtained

4. Drilling and Reaming – Radial drilling machine

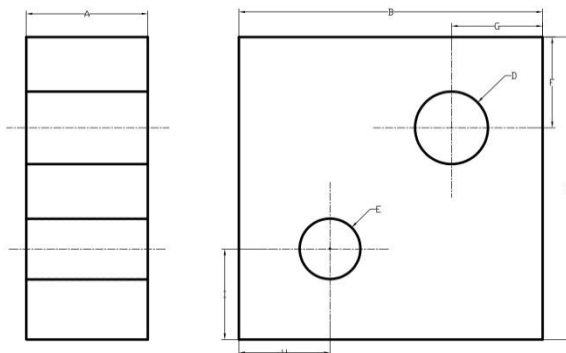

Dimensions			
Sl.No	Part Name	Actual	Obtained

BOARD EXAMINATION

Note: All the exercises in both sections have to be completed. Two exercises will be given for examination by selecting one exercise in each section. All the exercises should be given in the question paper and students are allowed to select by a lot.

Record note book should be submitted during examination.

Lathe	: 45 marks (2hours)
Procedure / Preparation	10
Machining / Dimensions	25
Surface Finishing	10
Drilling	: 25 marks (1 hour)
Procedure / Marking	10
Dimensions	10
Surface Finishing	5
Viva-voce	: 05 marks
Total	: 75 marks

LIST OF EQUIPMENT

Lathe Section

1. Lathe (Minimum 4 ½')	-	13 Nos.
2. All geared lathe	-	2 Nos.
3. 4 Jaw / 3 Jaw Chucks	-	Required Numbers
4. Chuck key	-	Required Numbers
5. Spanner	-	Sufficient quantity
6. Cutting Tools	-	Sufficient quantity
7. Pitch gauge	-	5 Nos.
8. Thread gauge	-	5 Nos.
9. Vernier Caliper	-	5 Nos.
10. Snap gauges	-	Sufficient quantity
11. Steel Rule (0-150)	-	Sufficient quantity
12. Calipers (Inside / Outside / Jenny)	-	Sufficient quantity
13. Dial Gauge with Magnetic Stand	-	Sufficient quantity
14. Marking Gauge	-	Sufficient quantity
15. Safety Glass	-	15 Nos.

Drilling Section

1. Upright drilling machine	-	2 Nos.
2. Radial drilling machine	-	1 No.
3. Drill bit & Tap set	-	Sufficient quantity
4. Reaming bit	-	Sufficient quantity
5. Counter sinking bit	-	Sufficient quantity
6. Counter boring bit	-	Sufficient quantity
7. Plug gauges	-	Sufficient quantity
8. Vernier Height Gauge	-	1 No.
9. Surface plate	-	2 Nos.



DIRECTORATE OF TECHNICAL EDUCATION
DIPLOMA IN AUTOMOBILE ENGINEERING

M SCHEME
2015 -2016 onwards

II YEAR
III SEMESTER

**32137 – STRENGTH OF MATERIALS AND
METROLOGY PRACTICAL**

CURRICULUM DEVELOPMENT CENTRE

STATE BOARD OF TECHNICAL EDUCATION & TRAINING, TAMILNADU

M-SCHEME

(Implemented for the students Admitted from the Year 2015-2016 on wards)

Course Name : DIPLOMA IN AUTOMOBILE ENGINEERING

Course Code : 1021

Subject Code : 32137

Semester : III

Subject Title : **STRENGTH OF MATERIAL AND METROLOGY PRACTICAL**

TEACHING AND SCHEME OF EXAMINATIONS:

No. of Weeks Per Semester: 15 Weeks

Subject	Instructions		Examination			Duration
	Hours/ Week	Hours/ Semester	Marks			
Strength of Materials and Metrology Practical	4	60	Internal Assessment	Board Examination	Total	3 Hrs
			25	75	100	

OBJECTIVES:

- Acquire skills on different types of testing methods of metals.
- Conduct material testing on elasticity, hardness, shear strength
- Familiarize the measuring techniques of Metrology instruments.
- Select the range of measuring tools.
- Obtain Accurate measurements.

Note:

The students should be given training in both sections (Part-A & Part-B). All the exercises should be completed and the students should maintain record notebook for the concerned exercise and submit during the Board Practical Examinations.

A. STRENGTH OF MATERIALS

Determine stress strain relations for steel.

Determine hardness of materials.

Perform torsion, impact and shear tests.

PART – A

Exercises

1. Test on Ductile Materials:

Finding Young's Modulus of Elasticity, yield points, percentage elongation and percentage

reduction in area, stress strain diagram plotting, tests on mild steel.

2. Hardness Test:

Determination of Rockwell's Hardness Number for various materials like mild steel, high carbon steel, brass, copper and aluminium.

3. Torsion test:

Torsion test on mild steel – relation between torque and angle of twist-determination of shear modulus and shear stress.

4. Impact test:

Finding the resistance of materials to impact loads by Izod test and Charpy test.

5. Tests on springs of circular section:

Determination of modulus of rigidity, strain energy, shear stress and stiffness by load deflection method (Open & Closed coil spring)

6. Shear test:

Single or double Shear test on M.S. bar to finding the resistance of material to shear load.

B. METROLOGY

Introduction to linear measurement

Introduction to angular measurement

Linear Measuring Instruments- Vernier Caliper, Micrometer, Vernier Height gauge, and Slip Gauge.

Angular Measuring Instruments – Universal Bevel Protractor, Sine Bar.

PART – B

Exercises:

I. LINEAR MEASUREMENTS:

1. Determine the measurement of the following using Vernier Caliper.
 - a. Thickness of ground MS flat
 - b. Diameter and length of cylindrical objects
 - c. Inside diameter of a bush component
2. Determine the diameter of a cylindrical component using micrometer and checking the result with digital micrometer.
3. Determine the height of gauge block or parallel bars using Vernier Height gauge and check with slip gauges
4. Determine the of a bore component using bore dial gauge.

II. ANGULAR MEASUREMENTS:

5. Determine the angle of V-block, Taper Shank of Drill and Dovetails in mechanical components using universal bevel protractor.
6. Determine the angle of machined surfaces of components using sine bar with Slip gauges.

BOARD OF EXAMINATION

Note: All the exercises should be given in the Board Examination and students are allowed to select by a lot. Each section should have adequate no. of instruments so as to do the exercises for a batch. Flexible timing is to be permitted to do their exercise in each section within 3 hours of duration.

SCHEME OF EXAMINATION

Exercises	Max. Marks
A. Strength of Materials	35 marks
Readings and Tabulation	: 20 Marks
Calculation and Result	: 15 Marks
B. Metrology	35 marks
Readings and Tabulation	: 20 Marks
Calculation and Result	: 15 Marks
Viva voce	05 marks
Total:	75 marks

LIST OF EQUIPMENTS

S.No	LIST OF THE TOOLS &EQUIPMENTS	QUANTITY REQUIRED
1.	UTM	01 No.
2.	Rockwell's Hardness Testing Machine	01 No.
3.	Torsion testing machine	01 No.
4.	Impact testing machine	01 No.
5.	Tension testing arrangements	01 No.
6.	Shear testing machine	01 No.
7.	Vernier calliper	05 Nos.
8.	Digital Micrometer	02 Nos.
9.	Vernier Height Gauge	02 Nos.
10.	Sine bar with Slip gauges	02 Nos.
11.	Universal Bevel Protractor	02 Nos.
12.	Bore Dial Gauge	02 Nos.



DIRECTORATE OF TECHNICAL EDUCATION
DIPLOMA IN AUTOMOBILE ENGINEERING

M SCHEME

2015 -2016 onwards

II YEAR

IV SEMESTER

32141 – THERMAL ENGINEERING

CURRICULUM DEVELOPMENT CENTRE

STATE BOARD OF TECHNICAL EDUCATION & TRAINING, TAMILNADU

M-SCHEME

(Implemented for the students Admitted from the Year 2015-2016 on wards)

Course Name : DIPLOMA IN AUTOMOBILE ENGINEERING

Course Code : 1021

Subject Code : 32141

Semester : IV

Subject Title : THERMAL ENGINEERING

TEACHING AND SCHEME OF EXAMINATIONS:

No. of Weeks per Semester: 15 Weeks

Subject	Instructions		Examination			Durations
	Hours/ Week	Hours/ Semester	Marks			
THERMAL ENGINEERING	6	90	Internal Assessment	Board Examination	Total	3 Hrs
			25	75	100	

TOPICS AND ALLOCATION OF HOURS

UNIT	TOPIC	TIME ALLOTTED (Hrs.)
I	Thermodynamics – properties of perfect gases – thermodynamics processes	17
II	Air cycles – Fuels and Combustion	17
III	Properties of steam – steam boiler – steam engine – steam condenser.	17
IV	IC engines – Performance of IC engines – Air compressors	16
V	Refrigeration – Air-conditioning	16
TEST & REVISION		7
TOTAL		90

RATIONALE:

The knowledge on the concept of Thermodynamics, Thermodynamic Processes, Air cycles, Fuels and Combustion of fuels, IC Engines, Air compressors, and steam properties, Boilers and Refrigeration and Air-conditioning system are vital to meet the current need of the Industries.

OBJECTIVES

- Explain the basics of systems, laws of thermodynamics and thermodynamic processes.
- Explain different types of Air Cycles.
- Explain the steam properties and Boilers
- Explain the performance of IC Engines, air compressors
- Explain the concepts and applications of Refrigeration and Air-conditioning.

32141 - THERMAL ENGINEERING DETAILED SYLLABUS

Contents: Theory

UNIT	Name of the topic	Hours
I	<p>Thermodynamics : Definition – fundamental units – derived units – SI units – Laws of motion – Newtons first law of motion - Newtons second law of motion - Newtons third law of motion – mass and weight – pressure – gauge and absolute pressure – temperature – absolute temperature – heat – specific heat – thermodynamic systems – properties of system – laws of thermodynamics – Zeroth law of thermodynamics – First law of thermodynamics – Second law of thermodynamics.</p> <p>Properties of perfect gases : Introduction – Laws of perfect gases – Boyle’s law – Charle’s law – general gas equation – Joule’s law – characteristic equation of gas – Avogadro’s law – Universal gas constant – Specific heats of a Gas – Specific heat at constant volume- Specific heat at constant pressure – relation between specific heats – ratio of specific heats.</p> <p>Thermodynamics processes of perfect gases : Constant volume process – constant pressure process – hyperbolic process – isothermal process – adiabatic process – polytropic process - throttling process- Derivation of heat transfer, change of internal energy, change of entropy and Work done – Simple problems.</p>	17
II	<p>Air cycles : Introduction – assumptions – classifications – efficiency of the cycle – reversible cycle – irreversible cycle – types of thermodynamic cycles – Carnot cycle – Joules cycle – Otto cycle – Diesel cycle – Dual combustion cycle – derivation – simple problems.</p> <p>Fuels: Classification – solid fuels – liquid fuels – gaseous fuels - merits and demerits – requirement of good fuel – calorific value of fuels – Higher calorific value – lower calorific value – Construction and working of bomb calorimeter and gas calorimeter.</p> <p>Combustion : Elements and compounds – atoms and molecules – atomic weight –</p>	17

	<p>molecular weight – combustion of solid fuels – combustion of gaseous fuels – theoretical</p> <p>weight of air required for complete combustion - theoretical volume of air required for complete combustion – Gravimetric analysis – Volumetric analysis – Weight of carbon in flue gases – weight of flue gases per kg of fuel burnt – Excess air supplied – weight of excess air supplied – flue gas analysis by Orsat Apparatus - simple problems.</p>	
III	<p>Properties of Steam: Formation of steam –Temperature vs Heat – Important terms for steam – latent heat of steam - dryness fraction – wetness fraction – types of steam – dry and saturated steam, wet steam and superheated steam – advantages of super heated steam - steam tables and their uses – Total heat – volume –internal energy – entropy – simple problems using steam tables. Measurement of dryness fraction of steam – barrel calorimeter – combined separating and throttling calorimeter – working principle - problems.</p> <p>Steam Boiler: Important terms – essentials of good steam boiler – selection of a steam boiler – classification – Working principle of Locomotive boiler – Lamont boiler – BHEL boiler – merits and demerits.</p> <p>Steam engine: Classification – important parts of steam engine – working of a single cylinder double acting reciprocating steam engine – theoretical indicator diagram – actual indicator diagram.</p> <p>Steam Condenser: Advantages of a condenser in steam power plant – Requirement – Classification – Working principle of Jet condenser – types – working principle of surface condenser - types.</p>	17
IV	<p>IC Engines :Introduction- classifications – four stroke cycle petrol and diesel engines- merits and demerits – two stroke cycle – petrol and diesel engines – comparison</p> <p>Performance of IC Engines : Performance of I.C engines - indicated power - brake power - friction power efficiencies of I.C engines- indicated thermal, brake thermal, mechanical and relative efficiencies - Morse test- procedure - problems - heat balance sheet – problems.</p> <p>Air compressors :Air Compressor – uses of compressed air- classifications of Air compressor-reciprocating compressor-single stage reciprocating compressor- multi stage compression – merits and demerits –Two stage compressor with imperfect cooling – with perfect inter cooling – rotary compressors – Roots blower – vane blowers – centrifugal and axial flow air compressors</p>	16
V	<p>REFRIGERATION : Refrigeration - refrigerators and heat pumps-types and applications of refrigeration - vapour compression refrigeration system - vapour absorption system – comparison – refrigerating effect - capacity of refrigerating unit - C.O.P - actual C.O.P – power required – mass of ice produced – problems - refrigerants-desirable properties - classification of refrigerants.</p> <p>AIR CONDITIONING: Air conditioning - psychrometric properties - dry air - moist air - water vapour - saturated air – dry bulb temperature - wet bulb depression - dew point</p>	16

	depression - dew point temperature – humidity - specific and relative humidity – psychrometric chart – psychrometric processes - sensible heating and cooling – humidification – dehumidification – classification and applications of air conditioning system – room air conditioning - central air conditioning – comparison – differences between comfort and industrial air conditioning - factors to be considered in air conditioning - loads encountered in air conditioning systems.	
--	--	--

Text Books

1 Applied Thermodynamics, P.K. Nag, 2nd Edition, TATA McGraw - Hill Publishing Co., New Delhi.

2 Thermal Engineering, R.S. Khurmi and J.K. Gupta, 18th Edition, S.Chand & Co, New Delhi

Reference Book

1 Thermal Engineering ,P.L Ballaney , 24th Edition ,Khanna Publishers, New Delhi.

2 Applied Thermodynamics, Domkundwar and C.PKothandaraman, 2nd Edition, Khanna publishers, New Delhi.

3 Refrigeration and Air conditioning, P. L. Ballaney, , 4th edition, Khanna Publishers, Newdelhi.

4 Power Plant Engineering Thermodynamics, Domkundwar and C.P Kothandaraman., 2nd Edition , Khanna Publishers.

5 Power plant Engineering, G.R. Nagpal, Khanna Publishers, New Delhi.



DIRECTORATE OF TECHNICAL EDUCATION
DIPLOMA IN AUTOMOBILE ENGINEERING

M SCHEME
2015 -2016 onwards

II YEAR
IV SEMESTER

32042 – SPECIAL MACHINES

CURRICULUM DEVELOPMENT CENTRE

STATE BOARD OF TECHNICAL EDUCATION & TRAINING, TAMILNADU

M-SCHEME

(Implemented for the students Admitted from the Year 2015-2016 on wards)

Course Name : DIPLOMA IN AUTOMOBILE ENGINEERING
Course Code : 1021
Subject Code : 32042
Semester : IV
Subject Title : SPECIAL MACHINES

TEACHING AND SCHEME OF EXAMINATIONS:

No. of weeks per semester: 15 Weeks

Subject	Instructions		Examination			Duration
	Hours /Week	Hours/ Semester	Marks		3 Hrs	
Special Machines	5	75	Internal Assessment	Board Examination		Total
			25	75	100	

Topics and Allocation of Hours:

Unit	Topics	Hours
I	Manufacturing of Plastic Components and Composite Manufacturing	14
II	Reciprocating Machines and Broaching Machine	14
III	Milling Machines and Gear Generating Processes	14
IV	Abrasive Process and Non- Conventional Machining Processes	13
V	CNC Machine and Its Components	13
	TEST AND REVISION	7
	Total	75

RATIONALE:

In the process of manufacturing we should possess adequate and through knowledge about the working of conventional as well as non conventional machines. The topics included aim to inculcate in the students the skills of metal cutting, milling, grinding, CNC machines and other machining processes which are very much essential for a technician to at promptly and with precision.

OBJECTIVES:

- Understand the plastic components and its process.
- Study the manufacturing of Composite materials.
- Study the working of various machine tools: Planer, Shaper and Slotter.
- Study the various work holding devices
- Study various types of milling cutter.
- Study the different types of grinders and grinding wheels.
- Study the broaching operation and their applications.
- Study the milling procedure for spur, helical and bevel gears.
- Study the various types of gear generating processes
- Study the use of non-conventional machining processes.
- Study the CNC machines working principle and its components.

32042 - SPECIAL MACHINES DETAILED SYLLABUS

Contents: Theory

Unit	Name of the Topic	Hours
I	MANUFACTURING OF PLASTIC COMPONENTS Plastic Components: Types of plastics - Engineering plastics – thermosets – composite - structural foam, elastomers - polymer alloys and liquid crystal polymers. Factors Influencing the Selection Of Plastics - Mechanical properties – degradation - wear resistance - frictional properties - special properties –processing – cost Processing of Plastics: Extrusion-general features of single screw extrusion -twin screw extruders. Injection moulding types: Plunger type - Reciprocating screw injection - details of injection mould - structural	14

	<p>foam injection mould - sandwich moulding - gas injection moulding - injection moulding of thermosetting materials - calendaring and rotational moulding. Design consideration for plastic components.</p> <p>Composite manufacturing: Introduction – characteristics of composite manufacturing - constituents – Glass fibers manufacturing process – hand laminating process – autoclave processing – filament winding – pultrusion process – liquid composite process – working principles by schematic diagram only – advantages – disadvantages.</p>	
II	<p>RECIPROCATING MACHINES</p> <p>Planer: Introduction - description of double housing planer – specifications -principles of operation – drives - quick return mechanism - feed mechanism - work holding devices and special fixtures - types of tools - operations.</p> <p>Shaper: Introduction – specifications – principles of operations standard shaper – quick return mechanism - crank and slotted link – hydraulic shaper - feed mechanism - work holding devices – fixture - operations.</p> <p>Slotter: Introduction – specifications - method of operation - Whitworth quick return mechanism - feed mechanism - work holding devices - types of tools.</p> <p>Broaching: Types of broaching machine - horizontal, vertical and continuous broaching - principles of operation - types of broaches – classification - broach tool nomenclature - broaching operations.</p>	14
III	<p>MILLING MACHINES AND GEAR GENERATING PROCESSES</p> <p>Milling Machines: Types - column and knee type – plain - universal milling machine - vertical milling machine - principles of operation - specification of milling machines - work holding devices - tool holding devices - arbor - stub arbor - spring collet – adapter. Milling cutters: cylindrical milling cutter - slitting cutter -side milling cutter - angle milling cutter - T-slot milling cutter - woodruff milling cutter - fly cutter - nomenclature of cylindrical milling cutter. Milling operations: straddle milling - gang milling - vertical milling attachment.</p> <p>Indexing plate – differential indexing - simple indexing – compound indexing – simple problems.</p>	14

	<p>Generating Process: gear shaper - gear hobbing - principle of operation only. Gear finishing processes: burnishing – shaving - grinding and lapping - gear materials.</p>	
IV	<p>ABRASIVE PROCESS AND NON- CONVENTIONAL MACHINING PROCESSES</p> <p>Abrasive Process: Types and classification – specifications - rough grinding – pedestal grinders - portable grinders - belt grinders - precision grinding - cylindrical grinder - centerless grinders – surface grinder - tool and cutter grinder - planetary grinders - principles of operations - grinding wheels – abrasives - natural and artificial diamond wheels - types of bonds - grit, grade and structure of wheels - wheel shapes and sizes - standard marking systems of grinding wheels - selection of grinding wheel - mounting of grinding wheels - Dressing and Truing of wheels - Balancing of grinding wheels.</p> <p>Non-Conventional Machining Processes: Construction, working and applications of Ultrasonic machining - chemical machining - electro chemical grinding - electrical discharge machining - plasma arc machining - LASER machining - Advantages – Disadvantages.</p>	13
V	<p>CNC MACHINE AND ITS COMPONENTS</p> <p>CNC Machines: Numerical control – definition – working principle of a CNC system – Features of CNC machines - advantage of CNC machines – difference between NC and CNC – Construction and working principle of turning centre – Construction and working principle of machining centre – machine axes conventions turning centre and machining centre – Coordinate measuring machine – construction and working principle.</p> <p>Components of CNC machine: Slide ways – requirement – types – friction slide ways and antifriction slide ways - linear motion bearings – recirculation ball screw – ATC – tool magazine – feedback devices – linear and rotary transducers – Encoders - in process probing - tool material – tool inserts.</p>	13

Text Book:

1. Elements of Workshop Technology- Vol. I & II, Hajra Choudry & Battacharya, Edn. 11, published by Media Promoters and Publishers Pvt. Ltd., Seervai Buildings `B`, 20-G, Noshir Bharucha Marg, Mumbai 400 007 – 2007.
2. Production Technology, Jain & Gupta, Khanna Publishers, 2-B, North Market, Naisarak, New Delhi – 110 006 – 2006.

Reference Book:

1. Production Technology, HMT, Edn. 18, published by Tata McGraw Hill Publishing Co. Ltd., 7, West Patel Nagar, New Delhi 110 008.
2. Manufacturing process, Myro N Begman, , Edn. 5, Tata McGraw Hill Publishing Co. Ltd., 7, West Patel Nagar, New Delhi 110 008.
3. Workshop Tech Vol I,II, III, WAJ. Chapman, published by Viva Books Pvt. Ltd., 4262/3, Ansari Road, Daryaganj, New Delhi 110 002.
4. Production processes, NITTTR, published by 5, Tata McGraw Hill Publishing Co. Ltd., West Patel Nagar, New Delhi 110 008.
5. Principles of the manufacturing of Composite materials – Suong V Hoa, DES tech publication. Inc, 439, North Duke street, Lancaster, Pennsylvania – 17602 U.S.A.



DIRECTORATE OF TECHNICAL EDUCATION
DIPLOMA IN AUTOMOBILE ENGINEERING

M SCHEME
2015 -2016 onwards

II YEAR
IV SEMESTER

32143 – AUTOMOBILE ENGINES

CURRICULUM DEVELOPMENT CENTRE

STATE BOARD OF TECHNICAL EDUCATION & TRAINING, TAMILNADU

M-SCHEME

(Implemented for the students Admitted from the Year 2015-2016 on wards)

Course Name : DIPLOMA IN AUTOMOBILE ENGINEERING

Course Code : 1021

Subject Code : 32143

Semester : IV

Subject Title : AUTOMOBILE ENGINES

TEACHING AND SCHEME OF EXAMINATIONS:

No. of Weeks per Semester: 15 Weeks

Subject	Instructions		Examination			Durations
	Hours/Week	Hours/Semester	Marks			
AUTOMOBILE ENGINES	6	90	Internal Assessment	Board Examination	Total	3 Hrs
			25	75	100	

TOPICS AND ALLOCATION OF HOURS

UNIT	TOPIC	TIME ALLOTTED (Hrs.)
I	ENGINE PRINCIPLES & FUNDAMENTALS	17
II	CONSTRUCTIONAL DETAILS OF ENGINE COMPONENTS	17
III	PETROL ENGINE FUEL SYSTEM	17
IV	DIESEL ENGINE FUEL SYSTEM	16
V	ENGINE COOLING AND LUBRICATION SYSTEM	16
TEST & REVISION		7
TOTAL		90

Rationale

To Impart the knowledge on basic concepts and fundamental principles of Petrol and Diesel Engines and its various sub components along with its function and to acquire knowledge about the automobile engine cooling and lubrication system.

Objectives

- Learn the construction and working fundamentals of IC Engines
- Performance of petrol and diesel engines and its components.
- Learn the working principle of fuel feed system of petrol and diesel engines.
- Acquire the knowledge on the lubrication and cooling systems of engines.
- Learn the various emissions in the automotive engines and its control methods.

32143 - AUTOMOBILE ENGINES

DETAILED SYLLABUS

Contents: Theory

UNIT	Name of the topic	Hours
I	ENGINE PRINCIPLES & FUNDAMENTALS Introduction to IC engines, Basic engine terminologies, Classification of IC engines, Engines Cycles (Otto & Diesel cycles), Petrol engines- construction & working of two stroke and four stroke petrol engines, construction and working of two stroke and four stroke diesel engines, Scavenging in two stroke cycle engines- crankcase scavenged engines and separately scavenged engines, Two stroke Vs Four stroke engines, Petrol Vs Diesel engines, Firing order -4,6 & 8 cylinders, Number and Arrangement of engine cylinders, Valve timing diagram for four stroke petrol engines and four stroke diesel engines, Port timing diagram for two stroke petrol and two stroke diesel engines, Automotive gas turbine & Wankel engine.	17
II	CONSTRUCTIONAL DETAILS OF ENGINE COMPONENTS Cylinder block & Crankcase, cylinder head, oil pan, manifolds, gaskets & its types cylinder liners- dry liner & wet liner, comparison of dry and wet liners, Functions of piston, piston materials, piston clearance, expansion controlling methods in piston, piston rings- types & functions, piston pin, connecting rod. Crankshafts-function, materials & construction, vibration dampers, engines bearings-requirements, bearing materials & main bearings, flywheel. Engine valves – types, arrangement of valves in engine, valve materials, valve cooling - sodium cooled valve, valve seats, valve guides, valve springs, valve actuating mechanisms, valve clearance, valve train component- camshaft, camshaft drive, valve tappet, push rod, rocker arm & rocker shaft, hydraulic valve lifter, variable valve timing technologies ,mufflers – types of mufflers used in automobiles.	17
III	PETROL ENGINE FUEL SYSTEM Petrol fuel- properties of petrol fuel, octane number, detonation, combustion stages in petrol engines, combustion chambers for petrol engines, Petrol fuel feed system- layout, construction and working of mechanical & electrical fuel pumps, air cleaners, fuel filters, fuel gauge, carburetion – principles – simple carburetor, carburetor circuits, Solex carburetors, SU Carburetor, Zenith Carburetor, petrol fuel injection – DTSI, CCVTI, PGMFI, MPFI systems.	17
IV	DIESEL ENGINE FUEL SYSTEM Diesel fuels – properties of diesel fuels, cetane number, diesel knock, and methods of controlling diesel knock, alternate fuels for automobile engines, combustion in diesel engines, combustion chambers for diesel engines.	16

	<p>Diesel fuel feed system- layout, components of diesel fuel feed systems, single acting fuel feed pump, double acting fuel feed pump, fuel injection pumps- jerk type and distributor type, diesel fuel filters, fuel heater and fuel-water separator - CRDI systems, fuel injectors- types, single and multi hole, pintle, pintaux nozzles – working of Glow plug - Governors – mechanical, pneumatic governors and electronic controlled governors- Superchargers and Turbochargers.</p>	
V	<p>ENGINE COOLING AND LUBRICATION SYSTEM</p> <p>Cooling system: Air cooling system- role of fins in air cooling system, water cooling system, comparison of air and water cooling systems, thermo-syphon and pump circulation in water cooling system, components of cooling system- thermostat (wax and bellow type) – water pump, radiator - cellular and tubular types, variable speed fan - types of engine coolants, anti freeze solutions.</p> <p>Lubrication System: Splash lubricating system, Pressure system , Dry sump lubrication system, pre lubrication system, Full flow and by pass systems, Characteristics of lubricating oils, classification & Identification of SAE oils, Filtering Systems — Oil Strainer – Oil pumps – Gear and Rotor type – Crescent type - Construction and operation -Pressure Relief Valve – Construction. Draft tube – Positive Crankcase Ventilation Systems – Construction. Vapour recovery cooling system Oil Cooler.</p>	16

Text Book

- 1 Internal Combustion Engines, “Ganesan.V”, Tata-McGraw Hill Publishing Co., New Delhi 1994.
- 2 Internal Combustion Engines Theory and Practice, “Dr.K.K.Ramalingam”, Scitech Publications(India) Pvt.Ltd, Chennai-17, 2001.
- 3 Engine Emission, “Springer and Patterson”, Plenum Press, 1990.

Reference Book

- 1 Internal Combustion Engine analysis and Practice, “Obert.E.F” International Text Book Co., Scranton, Pennsylvania, 1988.
- 2 Internal Combustion Engine Fundamentals, “Heywood.J.B”, McGraw Hill Book Co., 1995.
- 3 Internal Combustion Engines, “Taylor.C.F”, MIT Press, 1972
- 4 Automobiles and Pollution SAE Transaction, 1995
- 5 SAE Transactions, " Vehicle emission ", 1982 (3 volumes).



DIRECTORATE OF TECHNICAL EDUCATION
DIPLOMA IN AUTOMOBILE ENGINEERING

M SCHEME

2015 -2016 onwards

II YEAR

IV SEMESTER

32144 – AUTOTRONICS

CURRICULUM DEVELOPMENT CENTRE

STATE BOARD OF TECHNICAL EDUCATION & TRAINING, TAMILNADU

M-SCHEME

(Implemented for the students Admitted from the Year 2015-2016 on wards)

Course Name : DIPLOMA IN AUTOMOBILE ENGINEERING
Course Code : 1021
Subject Code : 32144
Semester : IV
Subject Title : AUTOTRONICS

TEACHING AND SCHEME OF EXAMINATIONS:

No. of Weeks per Semester: 15 Weeks

Subject	Instructions		Examination			Durations
	Hours/Week	Hours/Semester	Marks			
AUTOTRONICS	5	75	Internal Assessment	Board Examination	Total	3 Hrs
			25	75	100	

TOPICS AND ALLOCATION OF HOURS

UNIT	TOPIC	TIME ALLOTTED (Hrs.)
I	BASIC ELECTRICITY & MAGNETISM	14
II	BATTERY & IGNITION SYSTEMS	14
III	ELECTRICAL MACHINES (GENERATORS, ALTERNATOR, REGULATOR & STARTING MOTOR)	14
IV	LIGHTING, LAMP, HORN, GAUGE & WIRING	13
V	BASIC ELECTRONICS & COMPUTER APPLICATIONS IN AUTOMOBILE	13
TEST & REVISION		7
TOTAL		75

RATIONALE

Impart knowledge on Basic Electrical supply and safety. Learn the working of ignition system and the electrical components in the automotives. Acquire knowledge about the electronics applications in the automobile vehicle.

OBJECTIVE

To learn the basics of electrical and Laws.

To study about the electrical safety and importance of the earthing.

To study the construction and principle of DC motor and its types.

To understand about the generator, alternator, regulator and starting motor and mechanism.

To study about the different ignition system.

To study about the lead acid battery and testing.

To learn about the lighting system and its components in the automobile vehicle.

To study the horn, wins screen wiper, lamps and audio systems.

To study the electronic devices in the automotives.

To study about the sensors and electronic control unit.

32144 - AUTOTRONICS DETAILED SYLLABUS

Contents: Theory

UNIT	TOPICS	Hours
I	BASIC ELECTRICITY & MAGNETISM Definitions – charge, current, electromotive force, voltage, potential difference, inductance and capacitance. Explanations of electricity, properties of conductors, insulators and semiconductors, conventional theory of current flow & electron theory of current flow, Kirchoff's law & Ohm's law, resistance & resistivity of conductors, pulsating & pure direct currents, sinusoidal & non- sinusoidal alternating currents, peak average, RMS value of AC, frequency, wavelength, amplitude, time period, single phase & three phase AC power & power factor. Explanations of parallel(shunt) & series circuits involving source & loads, open & short circuits, importance of earthing on chassis in automotive wiring, Magnetism, magnetic flux density, magnetic field intensity, electromagnetic induction, Flemings' left hand & right hand rules, electromagnetic permeability, electromagnetic reluctance, application of electromagnetism in an automobile.	14

II	<p>BATTERY & IGNITION SYSTEMS</p> <p>Automobile electrical systems- generator, storage & distribution systems, starting system, ignition system, lighting system & accessories.</p> <p>Battery- lead acid battery- construction & working, battery rating, battery testing and battery charging methods.</p> <p>Requirements of ignition system, types of ignition system in engine, principles of working battery coil ignition with mechanical distributor, CB point controlled magneto ignition system, Electronic battery coil ignition systems & magneto ignition system through electrical circuit diagrams, difference between battery coil & magneto coil ignition systems</p> <p>Spark plug – types, characteristics & materials, importance of ignition timing, setting ignition timing, needs & types of advance mechanism- centrifuge – vacuum advance mechanism.</p>	14
III	<p>ELECTRICAL MACHINES (GENERATORS, ALTERNATOR, REGULATOR & STARTING MOTOR)</p> <p>Generator – Purposes – Construction – Field winding – Armature winding – Commutator – Brushes – Brush gears – Testing – Field winding – Armature –Growler testing – Brush – spring tension – Under cutting – Skimming commutator – Brush bedding.</p> <p>Alternator – Purpose – Construction – Body – Stator winding, Rotor winding, Slip rings – Brush - Advantages of alternator – trouble shooting in the alternator and armature.</p> <p>Regulator: Need for the regulator, Cut out or reverse cut out relay, Constant current and voltage regulator – compensated voltage regulator – trouble shooting in regulator – dynamo – principle.</p> <p>Starting motor – Need – Working Principle – Construction – Body – Field coil – Armature windings – Poles – Commutator and brush gears – Solenoid switch. Starting motor drive mechanism – Bendix – Over running clutch type drive & coaxial drive mechanism in the heavy vehicles – complete electrical circuits of heavy duty starting motor – First contact and second contact closing – Troubles – Causes & remedies – Electric Starting circuits in two wheelers.</p>	14
IV	<p>LIGHTING, LAMP, HORN, GAUGE & WIRING</p> <p>Lighting - Purpose and construction of each lamp holder bulbs – Head lamps –Head Lamp Beam setting and adjustments – Halogen lamps – Sealed beam, dip switch – Beam indicator – Fog lamp – Park lamp – Rear number plate lamp – Door Lamp – Pillar Lamp – Roof Lamp – Roof light – Fluorescent lamp in transport vehicles – brake light – Brake light switch – traffic indicators (Resistance & Transistor type) panel lamps.</p> <p>Horn – Construction – Working – Hum relay – Horn circuit, horn turning, Troubleshooting.</p> <p>Gauges – Fuel gauge – Oil pressure gauge – Coiling water temperature gauge – Ammeter charging indicator. Radio – Interface – Suppressors – Audio System – Wind screen wipers – Construction – Working – Trouble</p>	13

	<p>shooting Pneumatic type wind screen wipers.</p> <p>Wiring – Single pole – Double pole – Cable size color code – wiring harness – Cable connection – fuses – Circuit breakers – Window glass panel operating system.</p>	
V	<p>BASIC ELECTRONICS & COMPUTER APPLICATIONS IN AUTOMOBILE</p> <p>Semi conductor & semi conductor materials (Intrinsic & extrinsic), P type & N type semiconductors, junction diode, forward & reverse bias, knee voltage, maximum forward current, reverse breakdown voltage, zener diodes, transistors(NPN & PNP), Half wave & full wave rectifier, Logic gates- OR, AND, NOT, NAND, EXOR & EXNOR.</p> <p>Microprocessor control systems: Concept of CPU and computer memory used in automobiles. Sensors: pressure sensor, throttle position sensor, fuel flow sensor, thermistor sensor, oxygen sensor, speed sensors, knock detecting sensors solenoid and stepper motor. Electronic dashboard instruments - Onboard diagnosis system, security and warning system – ECU – principle and working of ECU.</p>	13

Text Book

- 1 Automotive electrical equipments, P.L.Kohli, Tata McGraw hill publications
- 2 Automobile Electrical and Electronics Systems, Tom Denton, Arnold, London

Reference Book

- 1 Automotive electrical equipment, A.P. Young and L.Griffidis, English language book society & New press
- 2 Automotive electrical equipment, W.H. Crouse, Mc. Graw hill book co. inc. New York
- 3 Automotive Electrical and electronic system, Bosch – SAE
- 4 Automotive Electronics and Electrical equipment by William H. Crouse and DL. Anglin, McGraw Hill company.
- 5 Modern Electrical Equipment of Automoblies, Judge. A.W. Chapman & Hall, London, 1992.
- 6 Automobile Electrical Equipment, Crouse. W.H., McGraw Hill Book Co. Inc., New York, 1980.
- 7 Automobile Engineering, KM Gupta, Umesh Publishers
- 8 Automobile Engineering, RB Gupta, Satya Prakashan, New Delhi



DIRECTORATE OF TECHNICAL EDUCATION
DIPLOMA IN AUTOMOBILE ENGINEERING

M SCHEME

2015 -2016 onwards

II YEAR

IV SEMESTER

32145 – THERMAL AND IC ENGINES PRACTICAL

CURRICULUM DEVELOPMENT CENTRE

STATE BOARD OF TECHNICAL EDUCATION & TRAINING, TAMILNADU

M-SCHEME

(Implemented for the students Admitted from the Year 2015-2016 on wards)

Course Name : DIPLOMA IN AUTOMOBILE ENGINEERING

Course Code : 1021

Subject Code : 32145

Semester : IV

Subject Title : THERMAL AND IC ENGINES PRACTICAL

TEACHING AND SCHEME OF EXAMINATIONS:

No. of Weeks per Semester : 15

Weeks

Subject	Instructions		Examination			
	Hours/ Week	Hours/ Semester	Marks			Durations
THERMAL AND IC ENGINES PRACTICAL	4	60	Internal Assessment	Board Examination	Total	3 Hrs
			25	75	100	

Note: All the experiments should be conducted and examination also to be conducted for all the exercises.

OBJECTIVES

To gain the practical exposure on Engine Ports and Valves timing

To study the Flash and the Fire points of a fuel

To find the Viscosity of lubricants.

To find the Calorific value of fuel

To conduct the performance test of engines

To analyze the emission gases

To study the various parts of an engine

To get an exposure on the assembly and functioning of various parts of fuel feed system.

PART A

1. Draw Port timing diagram
2. Draw Valve timing diagram
3. Find Flash and Fire point – open cup and closed cup
4. Find Viscosity of lubricating oil – Say bolt viscometer / Red wood viscometer

5. Find Calorific Value of liquid fuels.
6. Conduct the performance test on Petrol / Diesel engine and draw the performance curves.
7. Morse test on multi cylinder Petrol engine.
8. Find the percentage of CO, CO₂, O₂ and amount of HC, NO_x & smoke using exhaust gas analyzer.

PART B

1. Dismantling and assembling of the parts of a two stroke petrol engine.
2. Dismantling and assembling of the parts of a four stroke petrol and diesel engines.
3. Removing cam shaft, replacing timing gear, removing valves and adjusting valve Clearance.
4. Removing, servicing and replacing oil pump and water pump.
5. Removing, servicing and replacing of A.C mechanical fuel pump / S.U. electrical fuel pump.
6. Removing, servicing of SOLEX, SU carburetors and study the components in MPFI.
7. Dismantling and assembling of Diesel feed pump and study of components in CRDI.
8. Dismantling and assembling of distributor pump and injectors

BOARD EXAMINATION SCHEME OF EXAMINATION

Note: Question paper should have two questions, consist one from each part.

PART A	35
PART B	35
Viva Voice	5
TOTAL	75

THERMAL AND IC ENGINES PRACTICAL

Resources required:

Minimum one number is required for 60 intake. Based on the increase in intake the facility should be improved.

1. Basic and special tools of sufficient quantity.
2. Model for Port timing diagram / Valve timing diagram
3. Open cup apparatus and Closed cup apparatus
4. Say bolt viscometer
5. Red wood viscometer
6. Bomb Calorimeter
7. Petrol engine/ Diesel engine test rig to conduct load test
8. Diesel engine test rig to conduct load test
9. Multi cylinder Petrol engine test rig to conduct morse test.
10. Exhaust gas analyzer and smoke meter
11. Two stroke and Four stroke petrol and diesel engine.
12. Lubricating oil pump.
13. Water pump.
14. AC Mechanical fuel pump and S.U. electrical fuel pump.
15. SOLEX carburetor, SU carburetor, MPFI system and CRDI system.
16. Diesel fuel feed pump. (single acting / double acting)
17. Distributor pump.
18. Different types of Injectors.



DIRECTORATE OF TECHNICAL EDUCATION
DIPLOMA IN AUTOMOBILE ENGINEERING

M SCHEME
2015 -2016 onwards

II YEAR
IV SEMESTER

32046 – SPECIAL MACHINES PRACTICAL

CURRICULUM DEVELOPMENT CENTRE

STATE BOARD OF TECHNICAL EDUCATION & TRAINING, TAMILNADU

M-SCHEME

(Implemented for the students Admitted from the Year 2015-2016 on wards)

Course Name : DIPLOMA IN AUTOMOBILE ENGINEERING
Course Code : 1021
Subject Code : 32046
Semester : IV

TEACHING AND SCHEME OF EXAMINATIONS:

No. of weeks per semester: 15 Weeks

Subject	Instructions		Examination			Duration
	Hours /Week	Hours/ Semester	Marks			
Special Machines Practical	4	60	Internal Assessment	Board Examination	Total	3 Hrs
			25	75	100	

OBJECTIVES:

- Identify a milling machine and its parts
- Identify a cylindrical grinder, surface grinder and tool and cutter grinder
- Identify shaper, Slotter and its parts
- Identify the tools and instruments used in milling.
- Handle the different types of work holding devices
- Machine a component using different machine tools.
- Calculate the indexing for a work
- Machine a gear using milling machine.
- Machine a cutting tool using Tool and Cutter grinder.
- Machine a plug gauge using Cylindrical grinding machine.
- Machine components by shaping machine
- Machine components by slotting machine
- Prepare a record of work for all the exercises.

EXERCISES:

Raw Material: M.S. / C.I

1. Make 'V' Block using shaping machine

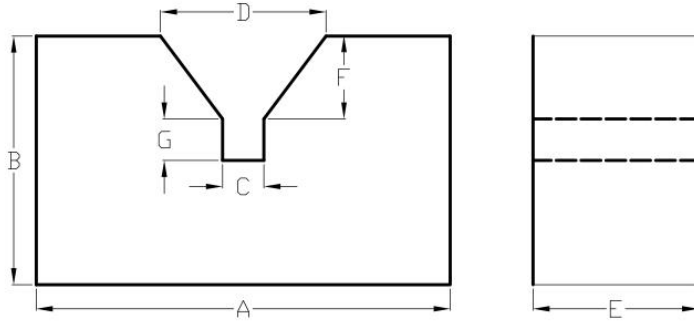

Dimensions			
Sl.No	Part Name	Actual	Obtained

2. Make dovetail using shaping machine

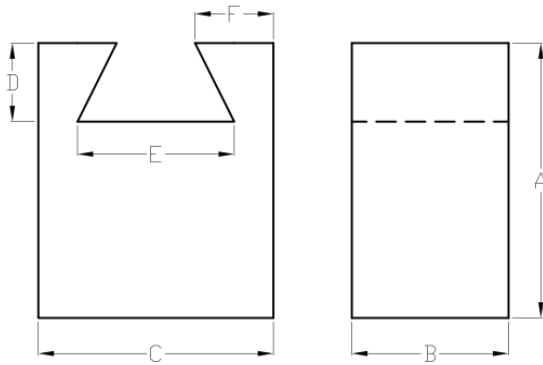

Dimensions			
Sl.No	Part Name	Actual	Obtained

3. Make groove cut using slotting machine

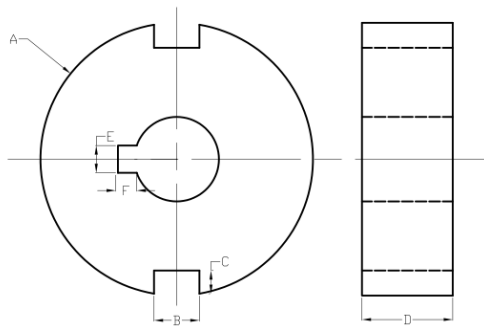

Dimensions			
Sl.No	Part Name	Actual	Obtained

4. Make round to square in milling machine.

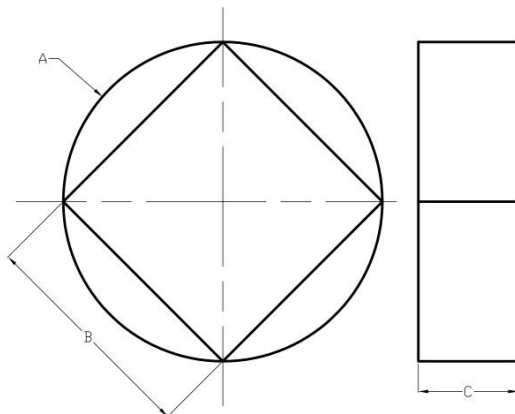

Dimensions			
Sl.No	Part Name	Actual	Obtained

5. Make Spur Gear using milling machine by Differential Indexing.

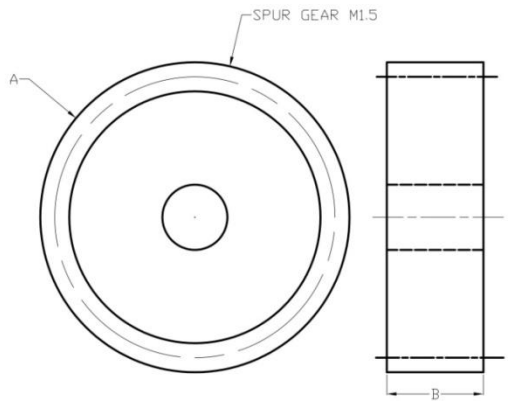

Dimensions			
Sl.No	Part Name	Actual	Obtained

6. Make Helical Gear using milling machine

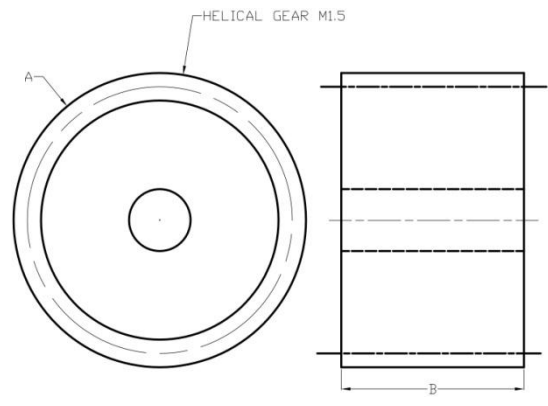

Dimensions			
Sl.No	Part Name	Actual	Obtained

7. Make slot cut using milling machine.

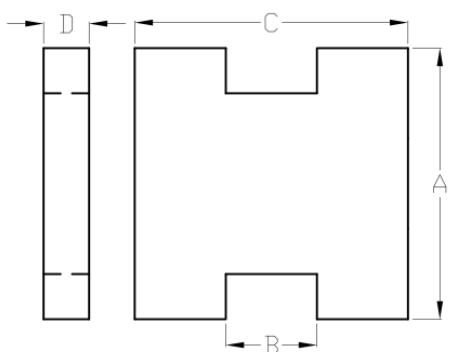

Dimensions			
Sl.No	Part Name	Actual	Obtained

8. Make Progressive type Plug gauge using Cylindrical Grinding machine

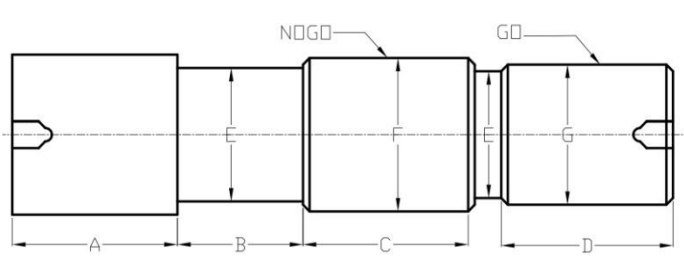

Dimensions			
Sl.No	Part Name	Actual	Obtained

9. Make a turning tool using Tool and Cutter Grinder

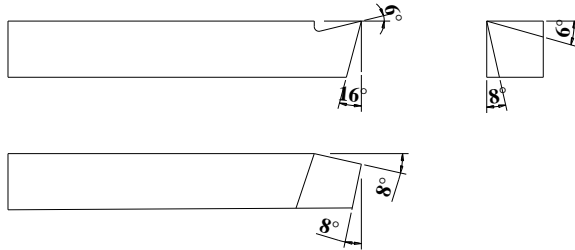

Dimensions			
Sl.No	Part Name	Actual	Obtained

10. Make plain surfaces (four surfaces) using surface Grinder

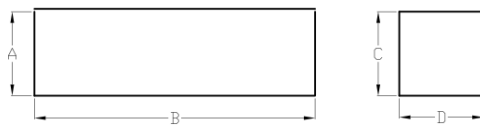

Dimensions			
Sl.No	Part Name	Actual	Obtained

BOARD EXAMINATION

Note: All the exercises should be given in the question paper and students are allowed to select by a lot. Record note book must be submitted for the examination.

ALLOCATION OF MARKS

Job preparation / Marking	15
Setting / Operations	30
Dimensions / Surface Finish	25
Viva voce	5
Total	75

LIST OF EQUIPMENTS

1. Vertical milling machine / Vertical attachment	-	2 Nos.
2. Universal Milling Machine	-	2 Nos.
3. Surface Grinding Machine	-	1 No.
4. Cylindrical Grinding Machine	-	1 No.
5. Tool and Cutter Grinder	-	1 No.
6. Shaping Machine	-	2 Nos.
7. Slotting Machine	-	1 No.
8. Tools and Measuring instruments	-	Sufficient quantity.
9. Consumables	-	Sufficient quantity



DIRECTORATE OF TECHNICAL EDUCATION
DIPLOMA IN AUTOMOBILE ENGINEERING

M SCHEME
2015 -2016 onwards

II YEAR
IV SEMESTER

32147 – AUTOTRONICS PRACTICAL

CURRICULUM DEVELOPMENT CENTRE

STATE BOARD OF TECHNICAL EDUCATION & TRAINING, TAMILNADU

M-SCHEME

(Implemented for the students Admitted from the Year 2015-2016 on wards)

Course Name : DIPLOMA IN AUTOMOBILE ENGINEERING
Course Code : 1021
Subject Code : 32147
Semester : IV
Subject Title : AUTOTRONICS PRACTICAL

TEACHING AND SCHEME OF EXAMINATIONS:

No. of Weeks per Semester: 15

Weeks

Subject	Instructions		Examination			Duration
	Hours/ Week	Hours/ Semester	Marks			
AUTOTRONICS PRACTICAL	4	60	Internal Assessment	Board Examination	Total	3 Hrs
			25	75	100	

Note:

The students should be given training in both sections (Part-A & Part-B). All the exercises should be completed and the students should maintain record notebook for the concerned exercise and submit during the Board Practical Examinations.

OBJECTIVES

To study the functions of a Battery

To study the various Electrical components of an automobile

To study the various Electronics components used in an automobile

**32147 - AUTOTRONICS PRACTICAL
Exercises**

Part - A

1. Removing, charging and replacing the Battery from a car.
2. Identification of various components of Ignition system. Dismantling and Overhauling of a Distributor, Setting Contact Breaker Points and Servicing of Spark Plugs.
3. Dismantling and Overhauling of a Starter Motor and a Dynamo.
4. Dismantling and Overhauling of an Alternator and Regulator.

5. Servicing and tune up of the Horn and Wiper Motor.
6. Measurement of voltage, current and resistance by using multi-meter (both analog and digital) in all ranges.

Part - B

1. Testing the Battery: Hydrometer Test – Open Circuit Voltage and High Rate Discharge Testing.
2. Adjust the Beam of the Head Lamp.
3. Adjust the Ignition Timing with Timing Light and Start the engine.
4. Draw the characteristics of PN diode.
5. Construction of a half wave and full wave rectifier without filter.
6. Construction of a bridge wave rectifier without a filter.

BOARD EXAMINATION - DETAILED ALLOCATION

Note: Question paper should have two questions one from each part.

PART A	25
PART B	45
Viva Voice	5
 TOTAL	 75

Resource required

All the components should be fitted on the frame / board

Battery Charger – 1 No.

Hydrometer, Specific gravity tester – 2 Nos each

Multimeter, - 2 Nos

The following items should be available as per the requirement – minimum 10 nos. each.

Transformer, Diode, Ammeter, Voltmeter, Load resistance, Connective wires, Bread board, DRB, Capacitor etc.



**DIRECTORATE OF TECHNICAL EDUCATION
DIPLOMA IN AUTOMOBILE ENGINEERING**

M SCHEME

2015 -2016 onwards

III YEAR

V SEMESTER

**32151 – INDUSTRIAL MANAGEMENT AND ROAD
TRANSPORT ORGANIZATION**

CURRICULUM DEVELOPMENT CENTRE

STATE BOARD OF TECHNICAL EDUCATION & TRAINING, TAMILNADU

M-SCHEME

(Implemented for the students Admitted from the Year 2015-2016 on wards)

Course Name : DIPLOMA IN AUTOMOBILE ENGINEERING
Course Code : 1021
Subject Code : 32151
Semester : V
Subject Title : INDUSTRIAL MANAGEMENT AND ROAD TRANSPORT ORGANISATION

TEACHING AND SCHEME OF EXAMINATIONS:

No. of Weeks per Semester: 15 Weeks

Subject	Instructions		Examination			Duration
	Hours/Week	Hours/Semester	Marks			
INDUSTRIAL MANAGEMENT AND ROAD TRANSPORT ORGANISATION	6	90	Internal Assessment	Board Examination	Total	3 Hrs
			25	75	100	

TOPICS AND ALLOCATION OF MARKS

UNIT	TOPIC	TIME ALLOTTED (Hrs.)
I	PRINCIPLES OF MANAGEMENT AND PERSONNEL MANAGEMENT	17
II	FINANCIAL MANAGEMENT AND MATERIAL MANAGEMENT	17
III	GOODS TRANSPORT OPERATION	17
IV	PASSENGER TRANSPORT OPERATION	16
V	MOTOR VEHICLES ACT, ROAD SIGNALS AND MARKETING MANAGEMENT	16
	TEST & REVISION	7
TOTAL		90

Rationale

Impart knowledge on principles of management, personnel management, financial management and material management. Acquire knowledge about the goods transport and passenger transport operations. Learn the motor vehicles act and marketing management.

Objective

To learn the principles of Management and personnel management.

To study about the financial management and material management.

To learn the Goods and Passenger transport operations.

To study about the motor vehicles act and marketing management.

32151 – INDUSTRIAL MANAGEMENT AND ROAD TRANSPORT ORGANIZATION DETAILED SYLLABUS

Contents: Theory

UNIT	Name of the topic	Hours
I	Principles of Management: Definition of management – Administration – Organisation – theories of management – F.W. Taylor's and Henry Fayol's principles – functions of manager – Planning – organizing – types of organization – line, staff, Taylor's pure functional types – line and staff and committee type-directing – leadership – types of leadership-qualities of a good leader – communication – formal and informal communication – motivation – positive and negative motivation – controlling – Just in time – Total Quality Management – Quality circle and Zero defect concept – Management Information Systems. Personnel Management: Responsibility of human resource management-policies and functions – selection procedure – training of workers – apprentice training, on the job training and vestibule school training – job evaluation and merit rating – objectives and importance – wages and salary administration-components of wages – wage fixation – types of wage payment- time rate systems – Halsey's 50% plan, rowan's System and Emerson's efficiency plan – problems.	17
II	Financial Management: Fixed and working capital – resources of capital – shares – types-preference and equity shares – debentures – types of debentures – public deposits, factory costing –direct cost – indirect cost-factory over head – fixation of selling price of a product – profit – problems-depreciation-causes-methods-straight line, sinking fund and percentage on diminishing value method – problems.	17

	Material Management: Objectives of a good stock control system- ABC analysis of inventory – procurement and consumption cycle- safety stock-re-order level – lead time – Economic order quality – problems – purchasing procedure – store keeping – Bin card.	
III	Goods Transport Operation: Simple layout of garages and depot for goods transport vehicle-materials Handling equipments in the goods vehicle depot-Receipt of goods, delivery of goods, insurance of goods and vehicles-settlement of claims-drivers duty schedules- vehicles schedule, log sheet-way bills and other documents – connected with goods vehicle operation-transhipments and sub contracting.	17
IV	Passenger Transport: administrative set up of a passenger transport organization, traffic investigation to improve services – peak hour demands – Application of C.P.M in evaluation of shortest operating distance of vehicle – classification of vehicles – express, limited stop, relief services, etc. – Fare table calculation – vehicle schedule in city service – drivers and conductors duty schedules – ticket system, trip sheet – incentive schemes for improving the service – operating cost.	16
V	Motor Vehicles Act, Road Signals: Motor vehicles Act and road signals – Definition of various vehicles – permit – insurance, road tax, etc. – procedure for registering a vehicle – fitness certificate – issue of non – road worthy certificate – inspection of accidents and recording – issue of driving license and conductor license – enforcement of emission norms – stage carriage – contract carriage – Mini bus definitions. Marketing Management: Consumer survey – salesmanship – Advertisement – channels of distribution – printing – wholesale and retail agencies – promotion – legal aspects – psychological and behavioral aspects – customer relationship – buying motive – closing the sale – market research – costing in road transport – Total cost – fixed cost – variable cost – running cost – overheads – control of costs – different methods.	16

Text Book

- 1 O. P. Khanna, Industrial Engineering and Management, Revised Edition – 2004, Dhanpat Rai, Publications (P) Ltd., 67/4 Madras House, Daryaganj, New Delhi 110 002.
- 2 T. R. Banga & S. C. Sharma, Engineering Economics and Management, Edn. 2 - 2001, published by McGraw Hill, New Delhi.

Reference Book

- 1 Heinz Wehrich, Harold Koontz, Management, A global perspective, 10th edition, McGraw Hill international edition 1994.
- 2 Joseph L. Massie, Essentials of Management, 4th Edition, Prentice-Hall of India, New Delhi 2004.
- 3 Goods vehicle Operation – Dunbar.
- 4 Bus Operation – Dunbar.
- 5 Tamilnadu Motor Vehicle Act 1989.



DIRECTORATE OF TECHNICAL EDUCATION
DIPLOMA IN AUTOMOBILE ENGINEERING

M SCHEME
2015 -2016 onwards

III YEAR
V SEMESTER

32152 – INDUSTRIAL AUTOMATION

CURRICULUM DEVELOPMENT CENTRE

STATE BOARD OF TECHNICAL EDUCATION & TRAINING, TAMILNADU

M-SCHEME

(Implemented for the students Admitted from the Year 2015-2016 on wards)

Course Name : DIPLOMA IN AUTOMOBILE ENGINEERING
Course Code : 1021
Subject Code : 32152
Semester : V
Subject Title : **INDUSTRIAL AUTOMATION**

TEACHING AND SCHEME OF EXAMINATIONS:

No. of Weeks per Semester : 15 Weeks

Subject	Instructions		Examination			Duration
	Hours/Week	Hours/Semester	Marks			
INDUSTRIAL AUTOMATION	6	90	Internal Assessment	Board Examination	Total	3 Hrs
			25	75	100	

TOPICS AND ALLOCATION OF MARKS

UNIT	TOPIC	TIME ALLOTTED (Hrs.)
I	FLUID POWER – PUMP AND MOTOR	17
II	CONTROL VALVES AND CIRCUITS	17
III	SELECTION OF DEVICES	17
IV	PNEUMATIC SYSTEM	16
V	PROGRAMMABLE LOGIC CONTROLLER	16
	Test & Revision	7
TOTAL		90

RATIONALE

Impart knowledge about the automation process in the automobile industries. To acquire knowledge about the hydraulic and pneumatic systems and its functions of the components. Understand the control methods of automation.

OBJECTIVES

To learn the types of chassis and axles.

To study about the steering system and its methods.

To understand the suspension systems and its components.

To learn the functions of universal joint and propeller shafts.

To study working principle of differential unit.

To learn about the types of brakes and tyres.

To know the function of clutch and gear box and its types

32152 - INDUSTRIAL AUTOMATION DETAILED SYLLABUS

Contents: Theory

UNIT	Name of the topic	Hrs
I	Fluid power – Pump and Motor Introduction to Fluid Power System and its basic components – Basic law – applications of fluid power – Advantages and drawbacks of fluid power. Classification – Positive displacement Pumps - Gear pump, Lobe pump, Vane pump, Piston pump – Pump performance – Pump noise – Pump selection. Cylinder mountings and mechanical linkages – Cylinder force, velocity and Power – Cylinder loads due to moving of weights – Cylinder loading through mechanical linkages – Hydraulic cylinder cushions and shock absorbers. Analysis of torque capacity – Gear motor – Vane motor – Piston motor – Hydraulic motor theoretical torque, power and flow rate – Hydraulic motor performance.	17
II	Control Valves and Circuits Pressure Control Valves (PCV): Simple pressure relief valve, Compound pressure relief valve, Pressure reducing valve, Unloading valve, Sequence valve, Counter balance valve. Flow Control Valves (FCV): Orifice as flow control valve, Needle valve, Pressure compensated and Non-pressure compensated valve. Direction Control Valves (DCV): Check valve, Pilot operated check valve, three-way valve, four-way valve: Manual/Mechanical/Solenoid operated valves. Servo valves: Definition – Mechanical-hydraulic servo valve – Electro-hydraulic servo valves. Accumulators: Reservoirs and accumulators – Types of accumulators – Charging and discharging of accumulators – Accumulator circuits. Deceleration circuit – Intensifier circuit – Regenerative circuit – Synchronizing circuit – Automatic cylinder reciprocating circuit – Sequencing circuit. Safety Circuits: Two-hand safety control circuit – Fail-safe control circuit by	17

	using emergency cut-off valve.	
III	<p>Selection of devices</p> <p>Selection of Hydraulic Cylinder: Speed of a hydraulic cylinder – Cylinder thrust – Acceleration and deceleration of cylinder loads – Local deceleration – Cylinder cushioning – Cylinder preferred sizes – Piston rod buckling.</p> <p>Selection of Hydraulic Motor: Hydro-static drives – Hydro-static drive characteristics – Braking of hydrostatic drives – Matching motor to load.</p> <p>Selection of Control Valves: Relief valves – Flow control valves – Direction control valves.</p> <p>Selection of Other Devices: Seals and its classification – Filters and its types – Filter location. Selection of filters – Selection of conduits - tubing and hoses – Selection of pump – Pressure losses – Reservoir and its design – Sizing of accumulator.</p>	17
IV	<p>Pneumatic system</p> <p>Comparison of pneumatic system with hydraulic system – Basic pneumatic system: Air filter, Pressure regulator, Lubricator and Muffler – Pneumatic valves: Direction control valve, Flow control valve, Shuttle valve, Two-pressure valve, Quick exhaust valve and Time delay valve.</p> <p>Cylinders – Air-motors and its types – Basic pneumatic circuits: Simple circuit, Material handling circuit.</p> <p>Hydro-pneumatics: Air-oil reservoir – Air-oil cylinder – Air-oil intensifier – Comparison of hydraulic, pneumatic and hydro-pneumatic systems. Advantages – Pneumatic sensors – Position sensors and its types – Pressure sensor – Switching elements. Operation of single-acting cylinder – Operation of double-acting cylinder – Air-pilot control of double- acting cylinder – Cylinder cycle timing system – Two-step speed control system – Two-handed safety control system – Control of air motor – Deceleration air cushion of cylinder.- circuit – Control of pneumatic cylinder using flip-flop.</p>	16
V	<p>Programmable Logic Controller</p> <p>Introduction to PLC – evolution – advantages – criteria for selection of suitable PLC – Block diagram of PLC – Programming devices – programming methods – STL and CSF, FBD and Ladder methods – simple instructions – programming NC and NO contacts – timer instructions – on-delay and off-delay timer – converting simple relay ladder diagram into PLC relay ladder diagram – PID and PWM functions. Simple PLC implementations for automatic star-delta starter and 4 floor lift system. Introduction and brief history of SCADA – hardware and software</p>	16

Text Books

- 1 Pneumatic Systems Principles and Maintenance, S.R. Majumdar – Tata McGraw Hill Pub co
- 2 Introduction to Programmable Logic Controllers, Gary Dunning - Thomson Delmar Learning Second Edition Second reprint 2003

Reference Book

- 1 Fluid Power by Harry L. Stewart – Audel Series
- 2 Hydraulics & Pneumatics Power for production Harry L Stewart – Industrial Press Inc, New York
- 3 Pneumatic circuit by Harry L. Stewart – Audel Series
- 4 Fundamentals of pneumatic control Engg – Text book By Festo
- 5 Introduction to Pneumatics – Test Book by Festo



DIRECTORATE OF TECHNICAL EDUCATION
DIPLOMA IN AUTOMOBILE ENGINEERING

M SCHEME
2015 -2016 onwards

III YEAR
V SEMESTER

**32153 – AUTOMOBILE CHASSIS AND
TRANSMISSION**

CURRICULUM DEVELOPMENT CENTRE

STATE BOARD OF TECHNICAL EDUCATION & TRAINING, TAMILNADU

M-SCHEME

(Implemented for the students Admitted from the Year 2015-2016 on wards)

Course Name : DIPLOMA IN AUTOMOBILE ENGINEERING
Course Code : 1021
Subject Code : 32153
Semester : V
Subject Title : **AUTOMOBILE CHASSIS AND TRANSMISSION**

TEACHING AND SCHEME OF EXAMINATIONS:

No. of Weeks per Semester: 15 Weeks

Subject	Instructions		Examinations			Duration
	Hours/ Week	Hours/ Semester	Marks		Total	
AUTOMOBILE CHASSIS AND TRANSMISSION	5	75	Internal Assessment	Board Examination	100	3 Hrs.
			25	75		

TOPICS AND ALLOCATION OF MARKS

UNIT	TOPIC	TIME ALLOTTED (Hrs.)
I	CHASSIS FRAME	14
II	CLUTCH and GEAR BOX	14
III	UNIVERSAL JOINT, PROPELLER SHAFT, DIFFERENTIAL	14
IV	STEERING SYSTEM and SUSPENSION SYSTEM	13
V	BRAKES AND TYRES	13
	TEST & REVISION	7
	TOTAL	75

RATIONALE

Impart the knowledge of Automobile Chassis is vital for growing need. Transmission of energy in the automobiles is an eminent area where a lot of concentration is given. The other systems like steering, suspension and braking which are allied with transmission are to be given due importance.

OBJECTIVES:

To learn the types of chassis and axles.

To study about the steering system and its methods.

To understand the suspension systems and its components.

To learn the functions of universal joint and propeller shafts.

To study working principle of differential unit.

To learn about the types of brakes and tyres.

To know the function of clutch and gear box and its types.

**32153-AUTOMOBILE CHASSIS AND TRANSMISSION
DETAILED SYLLABUS**

Contents: Theory

UNIT	Name of the topic	Hours
I	<p>CHASSIS FRAME, FRONT AND REAR AXLE Introduction of Chassis frame – classifications of chassis based on engine location - Layout of the Chassis and its main components - Functions of the Chassis frame - Types of Chassis frames - Various loads acting on the frame.</p> <p>Front axle construction – live and dead axle – beam and tubular construction- stub axle types – Elliot and reverse Elliot – Lemoine and Lemoine inverted –rear axle construction — floating axles – semi-floating – three quarter floating and full floating.</p>	14
II	<p>CLUTCH and GEAR BOX Clutch – function – clutch actuating mechanism – Mechanical and hydraulic types – clutch material – single plate dry clutch – dual plate dry clutch – multi plate wet clutch – semi centrifugal and centrifugal clutch – motor cycle clutch – Diaphragm clutch - fluid coupling and torque converter - Trouble shooting of Clutch.</p> <p>Gear Box – purpose – resistance offered to the motion of the vehicle – air resistance – rolling resistance – Resistance offered to the motion of the vehicle – gradient resistance – tractive effort – gear ratio – types of gear boxes – sliding mesh – constant mesh – synchromesh device – epicyclic – over drive – under drive and transfer cases – 4 wheel drive – gear shifting mechanism – floor shifting and steering column shifting – Automatic Gear box (CVT) - Trouble shooting of gear box.</p>	14
III	<p>UNIVERSAL JOINT, PROPELLER SHAFT, DIFFERENTIAL Universal Joints – variable velocity joint – constant velocity joints – cross or spider type – Rzeppa joints – Bendix Weiss type – tracta – centre joint –construction for heavy vehicles – propeller shaft two piece and three piece construction– Hotchkiss, torque tube, Torque arms – Shackles</p>	14

	types – final drive-function – types – Spiral, bevel, Hypoid – worm and worm wheel – Differential function – differential action – non slip differential – differential lock – Trouble shooting of final drive and differential.	
IV	<p>STEERING SYSTEM and SUSPENSION SYSTEM</p> <p>Steering system – Ackerman principle of steering – front end geometry – castor, camber, king pin inclination, toe-in, toe-out on turns – steering gear box – types – Marles cam and roller – cam and peg – recirculating ball – rack and pinion – power steering, linkage booster type, integral type – power steering pumps.</p> <p>Suspension system – rigid axle and independent suspension – function of spring and shock absorber – coil, leaf spring, torsion bar – Rubber spring- solid and laminated leaf spring types - air suspension – rear independent suspension antiroll bar – principle of knee action – shock absorbers – Telescopic type -Trouble shooting in suspension & steering systems.</p>	13
V	<p>BRAKES AND TYRES</p> <p>Brakes – function – stopping distance – Braking system – mechanical, hydraulic and air brake systems – brake shoes, primary and secondary shoes – servo action of brake shoes – drum and disc brakes – construction and operation master cylinder – single and Tandem master cylinder – wheel cylinders – bleeding of brakes – brake shoe adjustment mechanism – Micram adjusters – Snailcam, screw adjuster.</p> <p>Tyres and tubes – cross ply and radial ply – tubeless tyres – wheels – types –disc, split type, spoked and magna – purpose of tandem rear axle – trouble shooting of braking system and tyres – power brakes – Air and Air assisted Brake systems-Anti-lock brake system(ABS)- Exhaust Braking system</p>	13

Text Book

- 1 Automotive Transmission & Power Train – William H. Grouse.
- 2 Automotive Chassis and Body-William H. Grouse
- 3 Modern Transmission systems, Judge, A.W., Chapman and Hall Ltd., 1990.

Reference Book

- 1 Automobile Transmission Volume II – A.W.Judge.
- 2 Automotive Chassis, Heldt P.M., Chilton Co., New York, 1990
- 3 Motor Vehicles, Newton Steeds and Garret, 13th Edition, Butterworth, London, 2005.
- 4 Automobile engineering ,vol I – Dr.Kirpal singh – standard publishers – 10th edition 2007.
- 5 Passenger Car Automotive Transmissions”, Design Practices, SAE Hand book-1994.



DIRECTORATE OF TECHNICAL EDUCATION
DIPLOMA IN AUTOMOBILE ENGINEERING

M SCHEME

2015 -2016 onwards

III YEAR

V SEMESTER

32071 – TOTAL QUALITY MANAGEMENT
(ELECTIVE THEORY)

CURRICULUM DEVELOPMENT CENTRE

STATE BOARD OF TECHNICAL EDUCATION & TRAINING, TAMILNADU

M-SCHEME

(Implemented for the students Admitted from the Year 2015-2016 on wards)

Course Name : DIPLOMA IN AUTOMOBILE ENGINEERING
Course Code : 1021
Subject Code : 32071
Semester : V
Subject Title : TOTAL QUALITY MANAGEMENT

TEACHING AND SCHEME OF EXAMINATIONS:

No. of Weeks per Semester: 15 Weeks

Subject	Instructions		Examination			Duration
	Hours/ Week	Hours/ Semester	Marks			
Total Quality Management	5	75	Internal Assessment	Board Examination	Total	3 Hrs
			25	75	100	

Topics and Allocation of Hours:

Unit	Topics	Hours
I	Basic Concepts of Total Quality Management	14
II	Continuous process improvement – Q-7 Tools	14
III	Statistical Fundamentals	14
IV	Control charts	13
V	Management Planning tools & Bench marking	13
	REVISION AND TEST	7
	Total	75

RATIONALE:

Quality and customer satisfaction in every product and every activity is the order of the day. As there is a shift from quality control to quality management in all

activities, the concept Total Quality Management and the pillars of TQM are to be given to Engineers, who are designing products and production systems.

OBJECTIVES:

- Define quality and appreciate its signature.
- Explain the concept of TQM.
- Appreciate the use of principles of TQM to meet customer satisfaction.
- Solve problem using the Quality control tools.
- Apply Brainstorming and quality circle to solve problems.
- Use PDCA cycle for continuous improvement.
- Appreciate the benefits of implementing 5S concepts.
- Collect, classify and present the data.
- Determine the process capability of a manufacturing process.
- Practice on management planning tools.
- Use Bench Mark and JIT concepts.

**32071 - TOTAL QUALITY MANAGEMENT
DETAILED SYLLABUS**

Contents: Theory

Unit	Name of the Topic	Hours
I	BASIC CONCEPTS OF TOTAL QUALITY MANAGEMENT Quality-Definitions - Dimensions of quality - Brainstorming and its objectives - Introduction to TQM – Characteristics – Basic concepts – Elements – Pillars – Principles - Obstacles to TQM implementation – Potential benefits of TQM – Quality council – Duties – Responsibilities – Quality statements – Vision – Mission – Quality policy statements – Strategic planning – Seven steps to strategic planning – Deming philosophy- Customer delight - ISO 9001:2008 Quality Management System requirements and implementation.	14
II	CONTINUOUS PROCESS IMPROVEMENT – Q7 TOOLS Input / Output process model – Juran Trilogy – PDCA (Deming Wheel) cycle – 5S Concepts – SEIRI, SEITON, SEISO, SEIKETSU and SHITSUKE – needs and objectives – effective implementation	14

	<p>of 5S concepts in an organisation - Housekeeping – Kaizen.</p> <p>Seven tools of quality control (Q-7 tools) – Check sheet – Types of check sheet – Histogram – Cause and effect diagram - Pareto diagram – Stratification Analysis – Scatter diagram-Graph/run charts – Control charts - Construction of above diagrams.</p> <p>Quality circle - concept of quality circle - Organisation of Quality circle and objectives of Quality circle.</p>	
III	<p>STATISTICAL FUNDAMENTALS</p> <p>Types of Data – Collection of Data – Classification of Data – Tabular presentation of Data – Graphical representation of a frequency distribution – Comparison of Frequency distribution – Mean – Median – Mode – Comparison of measures of central tendency – Introduction to measures of dispersion – Sample – sampling - Normal curve – Sigma – Concept of six sigma – Principles – Process- Problems.</p>	14
IV	<p>CONTROL CHARTS</p> <p>Control chart – Types of control charts – Control chart for variables – Construction of X and R charts – control limits Vs specification limits – Process capability – Method of doing process capability Analysis – Measures of process capability – Problems.</p> <p>Attributes – Control charts – P chart – np chart – c chart – u chart – Construction of above diagrams – Problems - Comparison between variable chart and Attribute chart.</p>	13
V	<p>MANAGEMENT PLANNING TOOLS & BENCH MARKING</p> <p>Affinity diagram – Radar Diagram - Inter Relationship diagram (Inter Relationship diagram) – Tree diagram - Prioritization matrix – Matrix diagram – Decision tree – Arrow diagram – Matrix data analysis diagram - Construction of above diagrams.</p> <p>Bench marking – Objectives of bench marking – Types – Bench marking process - Benefits of Bench marking – Pit falls of Bench marking-Just In Time(JIT) concepts and its objectives - Total Productive Maintenance(TPM) - Introduction, Objectives of TPM - steps in implementing TPM.</p>	13

Text Book:

- 1) Total Quality Management, Date H.Besterfiled, Pearson Education Asia.
- 2) Total Quality Management, V.Jayakumar, Lakshmi Publications.(reprint 2005)
- 3) Training manual on ISO 9001 : 2000 & TQM, Girdhar J.Gyani, Raj Publishing House, Second Edition 2001
- 4) Quality Management, Howard Cuitlow, Tata Mc Graw Hill, 1998

Reference Book:

- 1) Total Quality Management, Oakiand.J.S. Butterworth Heinemann Ltd. Oxford 1989.
- 2) Quality Management – Concepts and Tasks- Narayana.V and Sreenivasan.N.S., New Age International 1996.
- 3) Total Quality Management for engineers, Zeiri. Wood Head Publishers. 1991.
- 4) Quality Planning and Analysis, Juran J.M and Frank M.Gryna Jr., TMH. India. 1982
- 5) ISO 9001, Brain Rethry, Productivity and Quality Publishing Pvt. Ltd. 1993.
- 6) Quality Auditing D.Mills, Chapman and Hall, 1993.



DIRECTORATE OF TECHNICAL EDUCATION
DIPLOMA IN AUTOMOBILE ENGINEERING

M SCHEME
2015 -2016 onwards

III YEAR
V SEMESTER

**32172 – ALTERNATIVE FUELS AND ENERGY
SYSTEMS
(ELECTIVE THEORY)**

CURRICULUM DEVELOPMENT CENTRE

STATE BOARD OF TECHNICAL EDUCATION & TRAINING, TAMILNADU

M-SCHEME

(Implemented for the students Admitted from the Year 2015-2016 on wards)

Course Name : DIPLOMA IN AUTOMOBILE ENGINEERING
Course Code : 1021
Subject Code : 32172
Semester : V
Subject Title : **ALTERNATE FUELS AND ENERGY SYSTEMS**

TEACHING AND SCHEME OF EXAMINATIONS:

No. of Weeks per Semester : 15 Weeks

Subject	Instructions		Examination			Duration
	Hours/ Week	Hours/ Semester	Marks			
Alternate Fuels And Energy System	5	75	Internal Assessment	Board Examination	Total	3 Hrs
			25	75	100	

TOPICS AND ALLOCATION OF MARKS

UNIT	TOPIC	TIME ALLOTED (Hrs.)
I	INTRODUCTION	14
II	ALCOHOLS	14
III	NATURAL GAS, LPG, HYDROGEN AND BIOGAS	14
IV	VEGETABLE OILS	13
V	ELECTRIC AND SOLAR POWERED VEHICLES	13
	Test & Revision	7
TOTAL		75

RATIONALE

Global scenario of alternate fuels is insisted for the betterment of the automobile industries. Keeping in the mind the various kinds of fossil fuels and their scarcity in near future, the necessity of searching for an alternate fuels become most important.

OBJECTIVES

To identify the different sources of fuels.

To study the fuels and their energy levels

To acquire knowledge of alternate fuels

To learn about the changes in the engine design

To study the various energy systems used in the automobiles.

32172-ALTERNATE FUELS AND ENERGY SYSTEM DETAILED SYLLABUS

UNIT	Contents	Hours
I	INTRODUCTION Estimation of petroleum reserve - World Energy Scenario - Energy Survey of India – Oil industry background and history – survey of oil consumption - Availability of petroleum products – types – uses - air craft fuels – alternate fuels – list of alternate fuels - Need for alternate fuel – Availability of alternate fuels.	14
II	ALCOHOLS Introduction - properties of alcohol as fuel - uses of alcohol fuels – alcohol availability – alcohol production – methanol – ethanol – impact of incremental vehicle cost – vehicle technology and vehicle emission – use of low level blends – vehicle emission – dedicated vehicles – fuel flexible vehicle – variable fuelled vehicle – air quality benefits of alcohol fuels – methanol vehicles – fuel characteristics – fuel additives – handling of methanol – methanol health and safety.	14
III	NATURAL GAS, LPG, HYDROGEN AND BIOGAS Availability of CNG - automotive gasoline – composition – types – properties – additives – effect of emissions - modification required in engines – performance and emission characteristics of CNG and LPG in SI & CI engines. Performance and emission for LPG – Hydrogen – Storage and handling, performance and safety aspects.	14
IV	VEGETABLE OILS Introduction - Various vegetable oils for engines – Etherification – Performance in engines – Performance and emission characteristics.	13
V	ELECTRIC AND SOLAR POWERED VEHICLES Layout of an electric vehicle – advantage and limitations – Specifications – System component, Electronic control system – High energy and power density batteries – Hybrid vehicle – Solar powered vehicles. Fuel cell vehicles.	13

Text Book

- 1 Internal combustion engine, Ramalingam. K.K., SciTech publications, Chennai, 2003.
- 2 Energy today & tomorrow, Maheswar Dayal, I & B Horish India, 1982.
- 3 Alternative Fuels Guide Book, Bechtold,R.L., SAE, 1997.

Reference Book

- 1 Power Plant Engineering, Nagpal, Khanna Publishers, 1991.
- 2 Alcohols and motor fuels progress in technology, Series No.19, SAE Publication USA 1980.
- 3 SAE Paper Nos.840367, 841156, 841333, 841334.
- 4 The properties and performance of modern alternate fuels – SAE Paper No.841210.
- 5 Automobile pollution, Dr.Saty kush, IVY Publishing House, Delhi – 110095.



DIRECTORATE OF TECHNICAL EDUCATION
DIPLOMA IN AUTOMOBILE ENGINEERING

M SCHEME

2015 -2016 onwards

III YEAR

V SEMESTER

**32173 – AUTOMOBILE MAINTENANCE AND
EMISSION CONTROL
(ELECTIVE THEORY)**

CURRICULUM DEVELOPMENT CENTRE

STATE BOARD OF TECHNICAL EDUCATION & TRAINING, TAMILNADU**M-SCHEME**

(Implemented for the students Admitted from the Year 2015-2016 on wards)

Course Name : DIPLOMA IN AUTOMOBILE ENGINEERING
Course Code : 1021
Subject Code : 32173
Semester : V
Subject Title : AUTOMOBILE MAINTENANCE AND EMISSION CONTROL

TEACHING AND SCHEME OF EXAMINATIONS:

No. of Weeks per Semester: 15 Weeks

Subject	Instructions		Examination			
	Hours/Week	Hours/Semester	Marks			Durations
AUTOMOBILE MAINTENANCE AND EMISSION CONTROL	5	75	Internal Assessment	Board Examination	Total	3 Hrs
			25	75	100	

TOPICS AND ALLOCATION OF HOURS

UNIT	TOPIC	TIME ALLOTTED (Hrs.)
I	INTRODUCTION TO AUTOMOBILE WORKSHOP & MAINTENANCE MANAGEMENT	14
II	ENGINE MAINTENANCE- REPAIR & OVERHAULING	14
III	CHASSIS MAINTENANCE-REPAIR & OVERHAULING	14
IV	MAINTENANCE OF FUEL SYSTEM, COOLING SYSTEMS, LUBRICATION SYSTEM	13
V	ENGINE EMISSIONS AND ITS CONTROL	13
	TEST & REVISION	7
TOTAL		75

**32173 – AUTOMOBILE MAINTENANCE AND EMISSION CONTROL
DETAILED SYLLABUS**

Contents: Theory

UNIT	Name of the topic	Hours
I	<p>INTRODUCTION TO AUTOMOBILE WORKSHOP & MAINTENANCE MANAGEMENT</p> <p>General shop safety- shop layout, shop safety rules and procedures, shop hazards and its control.</p> <p>General shop tools- wrenches, ratchets, sockets, screw drivers, pliers, hammers, mallets, punches, chisels, files, taps, dies, gear & bearing pullers, bushing & seal pullers and drivers.</p> <p>Shop equipments- Blow gun, bench grinder, trouble light, hydraulic press, floor jack, safety stands, vehicle lift, tire changer, circuit tester, multimeter, tachometer & volt-amp tester.</p> <p>Measuring instruments- Rules, feeler gauges, wire gauge, micrometers, outside micrometer, dial indicator, vernier caliper, depth gauge, pressure & vacuum gauges.</p> <p>Necessity of maintenance, types of maintenance- preventive maintenance system, scheduled maintenance system & breakdown maintenance system, General maintenance schedule- daily, weekly, monthly & periodic maintenance of various vehicles (2 wheelers, LMV & HMV).</p> <p>General automotive service procedure, maintenance of records, log sheets & other documents used in automobile workshops.</p>	14
II	<p>ENGINE MAINTENANCE- REPAIR & OVERHAULING</p> <p>Dismantling of engine components, cleaning methods, visual & dimensional inspection, servicing of cylinder head-checking for warpage, cracks, refacing by grinding or cutting, straightening cylinder head, servicing of cylinder block- measurement of ovality, taperedness, cylinder boring, honing process & changing of liners.</p> <p>Servicing of piston-piston & piston rings for wear, appearance, piston head for sign deposits & detonation, oversize piston, piston ring groove clearance, removal and fitting of rings, servicing of valves- valve failure, valve refacing, service of valve seat, valve seating pattern, lapping of valves, valve clearance & adjustments.</p> <p>Servicing of crankshafts & connecting rod, Engine tune-up & engine assembly.</p>	14
III	<p>CHASSIS MAINTENANCE-REPAIR & OVERHAULING</p> <p>Procedure for overhauling of clutch assembly, inspection & servicing of clutch components, clutch adjustments, checking clutch pedal free travel, trouble shooting of clutch.</p> <p>Servicing of gear box- checking for run out of main shaft & lay shaft, wear of synchroniser and worn bearing, checking oil seals & trouble shooting of gear box.</p>	14

	<p>Servicing of differential- repair procedure, checking & adjustment for ring gear run out, backlash in ring gear, tooth contact between ring gear & pinion, bearing pre load.</p> <p>Servicing and maintenance of braking system- inspection & repair of master cylinders, wheel cylinders, brake drum, brake discs, brake lining & brake pads, adjustment of hydraulic brakes- shoe clearance, brake pedal free travel, pedal to wall clearance, parking brake adjustment.</p> <p>Maintenance of steering & suspension systems</p> <p>Care of wheels, tires, retreading of tires, vulcanizing & tire rotation, procedure of computerised wheel alignment and wheel balancing.</p>	
IV	<p>MAINTENANCE OF FUEL SYSTEM, COOLING SYSTEMS, LUBRICATION SYSTEM</p> <p>Servicing of fuel system- visual inspection, checking & cleaning fuel injectors, air cleaner service, fuel filter service, electrical fuel pump service, fuel line service, fuel gauge service, calibration & pressure setting of fuel pumps & injectors.</p> <p>Maintenance of cooling system- pressure checking of cooling system, cooling system flushing, water pump service, radiator service, thermostat testing, anti corrosion & anti freeze solutions.</p> <p>Maintenance of lubrication system- checking oil level, changing engine oil, oil filter service, oil pan service, oil pump service & oil pressure testing.</p>	13
V	<p>ENGINE EMISSIONS AND ITS CONTROL</p> <p>Various emissions from Automobiles – formation & effects of pollutants on environment and human beings – Emission formation in SI engines – carbon monoxide – un burnt hydrocarbon – Nitric oxide – Lead particulate – Poly nuclear aromatic hydrocarbon emissions – Emission from C.I Engine – physical delay, chemical delay – significance – emission formation due to incomplete combustion – White, Blue and Black smokes – particulates – Noise pollution.</p> <p>Emission norms – EURO and INDIA, Controlling of pollutants from engine – catalytic converters, evaporative emission control, positive crank case ventilation system, EGR (Exhaust gas recirculation), Air injection, Exhaust gas analyser and Smoke meter.</p>	13

Text Books:

1. Automotive technology- service & maintenance by Don Knowles
2. Automotive service by Tim Gills, Delmar Publisher Inc.
3. Automotive mechanics by William H Course & Donald L Anglin.

Reference Books:

1. Advanced Engine Performance Diagnosis, James D Halderman, PHI - 1998.
2. Service Manuals from Different Vehicle Manufacturers.



DIRECTORATE OF TECHNICAL EDUCATION
DIPLOMA IN AUTOMOBILE ENGINEERING

M SCHEME
2015 -2016 onwards

III YEAR
V SEMESTER

32055 – PROCESS AUTOMATION PRACTICAL

CURRICULUM DEVELOPMENT CENTRE

STATE BOARD OF TECHNICAL EDUCATION & TRAINING, TAMILNADU

M-SCHEME

(Implemented for the students Admitted from the Year 2015-2016 on wards)

Course Name : DIPLOMA IN AUTOMOBILE ENGINEERING
Course Code : 1021
Subject Code : 32055
Semester : V
Subject Title : **PROCESS AUTOMATION PRACTICAL**

TEACHING AND SCHEME OF EXAMINATIONS:

No. of Weeks per Semester: 15 Weeks

Subject	Instructions		Examination			
	Hours/ Week	Hours/ Semester	Marks			Duration
Process Automation Practical	4	60	Internal Assessment	Board Examination	Total	3 Hrs
			25	75	100	

OBJECTIVES:

- Design and operate pneumatic circuits.
- Design and operate fluid power circuits
- Use PLC system and its elements for process control
- Familiarize the working of function blocks in PLC
- Use ON-Delay timer to control a motor
- Use OFF-Delay timer to control a motor
- Use counter function block (Up counter and Down counter)
- Control the automatic operation of pneumatic cylinder using PLC
- Record of work to be prepared.

Exercises

Pneumatics Lab.

1. Direct operation of single and double acting cylinder.
2. Operation of double acting cylinder with quick exhaust valve.
3. Speed control of double acting cylinder using metering-in and metering-out circuits.
4. Automatic operation of double acting cylinder in single cycle - using limit switch.
5. Automatic operation of double acting cylinder in multi cycle - using limit switch.

Hydraulics Lab.

1. Direct operation of double acting cylinder.
2. Direct operation of hydraulic motor.
3. Speed control of double acting cylinder metering-in and metering-out control.

PLC Lab.

1. Direct operation of a motor using latching circuit.
2. Operation of a motor using 'AND' logic control.
3. Operation of a motor using 'OR' control.
4. On-Delay control of a motor and Off –Delay control of a motor.
5. Automatic operation of a Double acting cylinder-single cycle.
6. Automatic operation of a Double acting cylinder-single cycle - forward, time delay, return.
7. Automatic operation of Double acting cylinder-Multi cycle.
8. Sequential operation of double acting cylinder and a motor.

Board of Examination

Note: All the exercises have to be completed. Two exercises will be given for examination by selecting one exercise from Pneumatics Lab. or Hydraulics lab. and one from PLC lab.

All the exercises should be given in the question paper and students are allowed to select by a lot.

Record note book should be submitted during examination.

Allocation of Marks

Part A: Pneumatics/Hydraulics lab by lot	- 35 marks
Part B: One question from PLC lab.	- 35 marks
Viva-voce	- 05 marks
Total	- 75 marks

LIST OF EQUIPMENTS

1. Pneumatic Trainer Kit – 2Nos
(All Cylinders, Control Valves, Limit switches and other accessories)
2. Hydraulics Trainer Kit – 1No.
(All Cylinders, Control Valves, Limit switches and other accessories)
3. PLC kit. – 2 Nos.
4. Computer with software – 5 Nos.



DIRECTORATE OF TECHNICAL EDUCATION
DIPLOMA IN AUTOMOBILE ENGINEERING

M SCHEME
2015 -2016 onwards

III YEAR
V SEMESTER

**32156 – AUTOMOBILE CHASSIS AND
TRANSMISSION PRACTICAL**

CURRICULUM DEVELOPMENT CENTRE

STATE BOARD OF TECHNICAL EDUCATION & TRAINING, TAMILNADU

M-SCHEME

(Implemented for the students Admitted from the Year 2015-2016 on wards)

Course Name : DIPLOMA IN AUTOMOBILE ENGINEERING
Course Code : 1021
Subject Code : 32156
Semester : V
Subject Title : AUTOMOBILE CHASSIS AND TRANSMISSION
PRACTICAL

TEACHING AND SCHEME OF EXAMINATIONS:

No. of Weeks per Semester: 15 Weeks

Subject	Instructions		Examinations			Duration
	Hours/Week	Hours/Semester	Marks		Total	
AUTOMOBILE CHASIS AND TRANSMISSION PRACTICAL	4	60	Internal Assessment	Board Examination		3 Hrs.
			25	75	100	

Note: All the experiments should be conducted. Two questions will be given by selecting one question from each part. **Necessary safety arrangement to be made to lift and carryout the experiments. The components should be fixed in the frame / table as per the requirement.**

Part A

1. Remove and replace the pressure plate and clutch plate, fingers adjustment and clutch plate relining.
2. Dismantle, inspect and assemble the sliding mesh gear box / constant mesh gear box to find the gear ratios.
- 3 Dismantle, inspect and assemble the synchromesh gear box / Epicyclical gear train to find the gear ratios.
4. Dismantle and assemble the rear axle and adjust wheel bearing.
5. Dismantle, assemble and adjust the steering gearbox and find gear ratio.
6. Dismantle, assemble the power steering.

Part B

7. Remove, inspect and refit the shock absorber.
8. Dismantle and assemble the leaf and coil spring.
9. Overhauling, adjusting and bleeding of Hydraulic system.
10. Remove the tyre for Vulcanizing the tubes and refit.
11. Check, measure and adjust the caster, chamfer, king pin inclination, toe-in and toe- out
12. Remove the wheel from the vehicle and balance the wheel using wheel balancing machine

BOARD EXAMINATION - DETAILED ALLOCATION

Note: Question paper should have two questions comprising one exercise from each part.

	Marks
PART A	30
PART B	40
Viva voice	5
Total	75

Resources required for 32156 Automobile Chassis and Transmission Practical

Minimum requirement for 60 in-take. The facility should be kept based on the intake.

For each experiment separate components are required.

- Sufficient quantity of tools and special equipments.
- Light vehicle chassis – 1 No.
- Single Plate dry clutch – 2 Nos.
- Sliding mesh gear box – 1 No.
- Constant mesh gear box – 1 No.
- Synchromesh gear box – 1 No.
- Epicyclic gear train – 1 No.
- Rear axle – 2 Nos.
- Steering gear box – 2 Nos.
- Differential – 2 Nos.
- Shock absorbers – 4 Nos.
- Leaf and coil spring – each 2 Nos.
- Hydraulic braking system fitted with frame – 2 Nos.
- Vulcanizing machine (Electrical type) – 2 Nos.
- Wheel alignment kit – 1 No.
- Wheel balancing machine – 1 No.
- Mechanical / Hydraulic press – 1 No.
- Hydraulic Jack / Screw Jack – 2 Nos.
- Hoist – 2 Nos.
- Trolley – 2 Nos.
- Spanners & Tools – 6 sets.



DIRECTORATE OF TECHNICAL EDUCATION
DIPLOMA IN AUTOMOBILE ENGINEERING

M SCHEME
2015 -2016 onwards

III YEAR
V SEMESTER

**30002 – LIFE AND EMPLOYABILITY SKILLS
PRACTICAL**
(Common to All Branches)

CURRICULUM DEVELOPMENT CENTRE

STATE BOARD OF TECHNICAL EDUCATION & TRAINING, TAMILNADU

DIPLOMA IN ENGINEERING – SYLLABUS – M Scheme

(Being implemented from the Academic Year 2016-2017 onwards)

Course Name : **All Branches of Diploma in Engineering and Technology and Special Programmes**

Subject Code : **30002**

Semester : **V**

Subject Title : **LIFE AND EMPLOYABILITY SKILLS PRACTICAL**

Teaching and Scheme of Examination: No. of Weeks per Semester: 15 Weeks

Subject	Instruction		Examination			
	Hours/Week	Hours/Semester	Marks			Duration
			Internal assessment	Board Examination	Total	
Life and Employability Skills	4 Hours	60 Hours	25	75	100	3 Hours

Topics and Allocation of Hours:

Sl. No.	Section	No. of Hours
1	Part – A Communication	30
2	Part – B Entrepreneurship, Project Preparation, Productivity, Occupational Safety, Health, Hazard, Quality Tools& Labour Welfare	20
3	Part – C Environment, Global Warming, Pollution	10
TOTAL		60

RATIONALE

Against the backdrop of the needs of the Industries, as well as based on fulfilling the expectations of the Industries, the Diploma Level students have to be trained directly and indirectly in toning up their competency levels. Proficiency in Communication only, equips them with confidence and capacity to cope with the employment. Hence, there is a necessity to focus on these in the curriculum. At the end of the Course, the student is better equipped to express himself in oral and written communication effectively.

SPECIFIC INSTRUCTIONAL OBJECTIVES

- 1. Emphasize and Enhance Speaking Skills**

- 2. Increase Ability to Express Views & Opinions**

- 3. Develop and Enhance Employability Skills**

- 4. Induce Entrepreneurship and Plan for the Future**

- 5. Expose & Induce Life Skills for Effective Managerial Ability**

LIFE AND EMPLOYABILITY SKILLS PRACTICAL

SYLLABUS

Unit	Topics	Activity	Hours
I	Communication, Listening, Training, Facing Interviews, Behavioural Skills	-- instant sentence making – say expressions/phrases-- self- introduction/another higher official in company – describe/explain product – frame questions based on patterns – make sentences based on patterns	30
II	Entrepreneurship, Project Preparation, Marketing Analysis, Support & Procurement	-- prepare an outline of a project to obtain loan from bank in becoming an entrepreneur – prepare a resume	10
III	Productivity – comparison with developed countries, Quality Tools, Circles, Consciousness, Management, House Keeping	-- search in the website -- prepare a presentation – discuss & interact	05
IV	Occupational Safety, Health Hazard, Accident & Safety, First-Aid, Labour Welfare Legislation, Welfare Acts	-- search in the website -- prepare a presentation – discuss & interact	05
V	Environment, Global Warming, Pollution	-- taking down notes / hints – answering questions -- fill in blanks the exact words heard	10

LEARNING STRUCTURE

100 Marks

- Focus more on Speaking & Listening Skills
- Attention less on Reading & Writing Skills
- Apply the skills in fulfilling the Objectives on Focused Topics

a) Listening	25 Marks
1. Deductive Reasoning Skills (taking down notes/hints)	10
2. Cognitive Skills (answering questions)	10
3. Retention Skills (filling in blanks with exact words heard)	05
b) Speaking Extempore/ Prepared	30 Marks
1. Personality/Psychological Skills (instant sentence making)	05
2. Pleasing & Amiable Skills (say in phrases/expressions)	05
3. Assertive Skills (introducing oneself/others)	05
4. Expressive Skills (describe/explain things)	05
5. Fluency/Compatibility Skills (dialogue)	05
6. Leadership/Team Spirit Skills (group discussion)	05
c) Writing & Reading	20 Marks
1. Creative & Reasoning Skills (frame questions on patterns)	05
2. Creative & Composing Skills (make sentences on patterns)	05
3. Attitude & Aim Skills (prepare resume)	05
4. Entrepreneurship Skills (prepare outline of a project)	05
d) Continuous Assessment (Internal Marks)	25 Marks
(search,read, write down, speak, listen, interact & discuss)	
1. Cognitive Skills (Google search on focused topics)	
2. Presentation Skills& Interactive Skills (after listening, discuss)	
Note down and present in the Record Note on any 5 topics	10 Marks
Other activities recorded in the Record note	10 Marks
Attendance	05 Marks
INTERNAL MARKS	25 MARKS
EXTERNAL MARKS AT END EXAMINATION	75 MARKS

MODEL QUESTION

Time: 3 Hours

Maximum Marks: 75

A. LISTENING

25 Marks

1. Listen to the content and take down notes/hints 10
2. Listen to the content and answer the following questions. 10
3. Listen to the content and fill in the blanks the exact words heard. 05

B. SPEAKING

30 Marks

1. Say in a sentence instantly on hearing the word(5 words, one after another). 05
2. Say any five expressions commonly used in communication. 05
3. Imagine, a consultant has come to your department.
Introduce him to your subordinates. 05
4. Explain/describe the product you are about to launch in the market. 05
5. Speak with your immediate boss about the progress you have made. 05
6. Discuss within the group on the topic of focus in the syllabus. 05

C. WRITING & READING

20 Marks

1. Frame new questions from the pattern given by changing sets of words with your own. 05

a.	When	do	you	return?
b.	How	is	his performance?	
c.	Where	has	the manager	gone?
d.	What	is	the progress	today?
e.	Why	are	the machines	not functioning?

2. Make sentences from the pattern given by changing sets of words with your own. 05

a.	The workers	are	on strike		
b.	The labourers	are paid	well	in this factory	
c.	There	is	a rest room	for the workers	
d.	These	are	the new products	launched	by our company
e.	Almost everyone	come	to the company	on motorbikes	

3. Prepare a resume for the post of Department Manager. 05

4. Prepare an outline of a project to obtain a loan. (Provide headings and subheadings) 05

I. Guidelines for setting the question paper:

A. LISTENING :

ONLY TOPICS related to
POLLUTION /
ENVIRONMENT /
GLOBAL WARMING are to be taken.

These topics are common for all the three types of evaluation.

B. SPEAKING :

1. WORDS of common usage
2. Fragments – expression of politeness, courtesy, cordiality
3. Introduce yourself as an engineer with designation or
Introduce the official visiting your company/department
4. Describe/Explain the product/machine/department
5. Dialogue must be with someone in the place of work.
6. Group of six/eight
Discuss the focused topic prescribed in syllabus

C. WRITING & READING:

1. Provide five different structures.
Students are to substitute at least one with some other
word/words
2. Provide five different structures.
Students are to substitute at least one with some other
word/words
3. Provide some post related to industries.
4. Outline of the project (skeleton/structure)
Only the various headings and subheadings
Content is not needed

II. Guidelines for recording the material on the Focused Topics in the Record note.

Write in the record note, **on any five topics**, from the list of topics given below. **10 Marks**
(5 topics x 10 marks = 50 marks. Thus, the **Average of 5 topics is 10 Marks**)

1. Productivity in Industries – Comparison with developed countries
2. Quality Tools, Quality Circles and Quality Consciousness
3. Effective Management
4. House Keeping in Industries
5. Occupational Safety and Hazard

6. Occupational Accident and First Aid
7. Labour Welfare Legislations
8. Labour Welfare Acts and Rights
9. Entrepreneurship
10. Marketing Analysis, Support and Procurement

LABORATORY REQUIREMENT:

1. An echo-free room
2. Necessary furniture and comfortable chairs
3. A minimum of two Computers with internet access
4. A minimum of two different English dailies
5. A minimum of Three Mikes with and without cords
6. Colour Television (minimum size – 29”)
7. DVD/VCD Player with Home Theatre speakers
8. Smart board
9. Projector

Suggested Reading:

1. Production and Operations Management by S.N. Chary, TMH
2. Essentials of Management by Koontz & Wehrich, TMH
3. Modern Production / Operations Management by E.S. Buffa and R.K. Sarin, John Wiley & Sons
4. Production Systems: Planning, Analysis and Control by J.L. Riggs, 3rd ed., Wiley.
5. Production and Operations Management by A. Muhlemann, J. Oakland and K. Lockyer, Macmillan
6. Operations Research - An Introduction by H.A. Taha, Prentice Hall of India
7. Operations Research by J.K. Sharma, Macmillan
8. Business Correspondence & Report Writing by R.C. Sharma and K. Mohan, TMH
9. How to prepare for Group Discussion & Interview (With Audio Cassette) by Prasad, TMH
10. Spoken English – A self-learning guide to conversation practice (with Cassette)
11. Introduction to Environmental Engineering by Mackenzie, L. Davis and A. David, Cornwell, McGrawHill, 3rd Ed.
12. Environmental Engineering by Peary, Rowe and Tchobanoglous, McGrawHill
13. Total Quality Management – An Introductory Text by Paul James, Prentice Hall
14. Quality Control and Applications by Housen & Ghose
15. Industrial Engineering Management by O.P. Khanna



DIRECTORATE OF TECHNICAL EDUCATION
DIPLOMA IN AUTOMOBILE ENGINEERING

M SCHEME

2015 -2016 onwards

III YEAR

VI SEMESTER

**32161 – AUTOMOBILE BODY BUILDING
ENGINEERING**

CURRICULUM DEVELOPMENT CENTRE

STATE BOARD OF TECHNICAL EDUCATION & TRAINING, TAMILNADU

M-SCHEME

(Implemented for the students Admitted from the Year 2015-2016 on wards)

Course Name : DIPLOMA IN AUTOMOBILE ENGINEERING

Course Code : 1021

Subject Code : 32161

Semester : VI

Subject Title : AUTOMOBILE BODY BUILDING ENGINEERING

TEACHING AND SCHEME OF EXAMINATIONS:

No. of Weeks per Semester : 15 Weeks

Subject	Instructions		Examination			
	Hours/Week	Hours/Semester	Marks			Durations
AUTOMOBILE BODY BUILDING ENGINEERING	6	90	Internal Assessment	Board Examination	Total	3 Hrs
			25	75	100	

TOPICS AND ALLOCATION OF HOURS

UNIT	TOPIC	TIME ALLOTTED (Hrs.)
I	CAR BODY BUILDING ENGINEERING	17
II	BUS BODY BUILDING ENGINEERING	17
III	COMMERCIAL VEHICLES CONSTRUCTION ENGINEERING	17
IV	VEHICLE AERO DYNAMICS	16
V	BODY MATERIALS, MAINTENANCE AND SURFACE FINISH	16
	TEST & REVISION	7
TOTAL		90

**32161 – AUTOMOBILE BODY BUILDING ENGINEERING
DETAILED SYLLABUS**

Contents: Theory

UNI T	Name of the topic	Hours
I	CAR BODY BUILDING ENGINEERING Types of car bodies-saloon convertibles, Limousine, estate van, racing car and sports car-Visibility regulations, drivers visibility-methods of improving visibility and space in cars-Safety: safety design, safety equipments for car body construction, safety belts, Airbags.	17
II	BUS BODY BUILDING ENGINEERING Types of bus bodies: minibus, singledecker, double decker two level, split level and articulated bus-Bus body lay out: Floor height engine location-entrance and exit location-constructural details: Types of metal sections used-Regulations conventional and integral type construction, modular construction.	17
III	COMMERCIAL VEHICLES CONSTRUCTION ENGINEERING Different types of commercial vehicle LCV, MCV, HCV bodies-Light commercial vehicle body types- constructural details of flat platform body, Tipper body and Tanker body-Dimension of driver's seat in relation to controls-Drivers cabin design.	17
IV	VEHICLE AERO DYNAMICS Objectives-Vehicle drag and types, various types of forces and moments-effects of forces and moments-various body optimization techniques for minimum drag-Wind tunnel testing-Flow visualization techniques, scale model testing. Component balance to measure forces and moments.	16
V	BODY MATERIALS, MAINTENANCE AND SURFACE FINISH Body Materials & Maintenance: Steel sheet, Aluminium, Timber, Plastics, GRP, PRP properties of materials – corrosion-Anti corrosion methods – Body panel ,tools for repairing, Tinkering ,soldering and use of metalloid paste. Surface finish: Painting process – Electroplating of component – Vaccum coating, Electrostatic painting.	16

Text book:

1.PowloskiJ, Vehicle Body Engg. Bussiness Books Ltd,1989.

Reference :

1.CilesG.J. Body Construction & Design Books Butter Worth & co.

2.Jhon Fenton, Vehicle Body Layout and analysis Mechanical Engg Publication Ltd. London.



DIRECTORATE OF TECHNICAL EDUCATION
DIPLOMA IN AUTOMOBILE ENGINEERING

M SCHEME

2015 -2016 onwards

III YEAR

VI SEMESTER

**32062 – COMPUTER AIDED DESIGN AND
MANUFACTURING**

CURRICULUM DEVELOPMENT CENTRE

STATE BOARD OF TECHNICAL EDUCATION & TRAINING, TAMILNADU

M-SCHEME

(Implemented for the students Admitted from the Year 2015-2016 on wards)

Course Name : DIPLOMA IN AUTOMOBILE ENGINEERING
Course Code : 1021
Subject Code : 32062
Semester : VI
Subject Title : COMPUTER AIDED DESIGN AND MANUFACTURING

TEACHING AND SCHEME OF EXAMINATIONS:

No. of weeks per semester: 15 Weeks

Subject	Instructions		Examination			Duration
	Hours / Week	Hours / Semester	Marks			
Computer Aided Design and Manufacturing	5	75	Internal Assessment	Board Examination	Total	3 Hrs
			25	75	100	

Topics and Allocation of Hours:

Unit	Topics	Hours
I	COMPUTER AIDED DESIGN	14
II	COMPUTER AIDED MANUFACTURING	14
III	CNC PROGRAMMING, RAPID PROTOTYPING	14
IV	COMPUTER INTEGRATED MANUFACTURING, FLEXIBLE MANUFACTURING SYSTEMS, AUTOMATIC GUIDED VEHICLE, ROBOT	13
V	CONCURRENT ENGINEERING, QUALITY FUNCTION DEPLOYMENT, PRODUCT DEVELOPMENT CYCLE, AUGMENTED REALITY.	13
	REVISION AND TEST	7
	Total	75

RATIONALE:

As per the latest requirements in the Industries this enables to learn the assistance of computer in the field of design and manufacturing areas. It's able to learn the latest manufacturing concepts of in the shop floors and manufacturing methods like RPT. They are able to know about the CNC programming techniques are included.

OBJECTIVES:

- Understand the concept and requirement of the integration of the design and manufacturing.
- Acquire knowledge about the computer assistance in the design process and analysis.
- Understand the concepts of manufacturing with computer assistance in the shop floor.
- Understand the principle of latest manufacturing machines like RPT.
- Acquire the knowledge in the material handling equipment and robot.
- Understand the Computer Integrated Manufacturing and FMS.
- Study of Concurrent Engineering and its tools and Augmented Reality.

32062 - COMPUTER AIDED DESIGN AND MANUFACTURING DETAILED SYLLABUS

Contents: Theory

Unit	Name of the Topic	Hours
I	COMPUTER AIDED DESIGN Computer Aided Design: Introduction – definition – Shigley's design process – Ohsguga Model - CAD activities – benefits of CAD - CAD software packages. Transformations: 2D & 3D transformations – translation, scaling, rotation and concatenation. Geometric modelling: Techniques - Wire frame modelling – applications – advantages and disadvantages. Surface modelling – types of surfaces – applications – advantages and disadvantages – Solid modelling – entities – advantages and disadvantages – Boolean	14

	<p>operations - Boundary representation – Constructive Solid Geometry – Comparison.</p> <p>Graphics standard: Definition – Need - GKS – OpenGL - IGES – DXF.</p> <p>Finite Element Analysis: Introduction – Development - Basic steps – Advantage.</p>	
II	<p>COMPUTER AIDED MANUFACTURING</p> <p>Computer Aided Manufacturing: Introduction - Definition – functions of CAM – benefits of CAM.</p> <p>Group technology: Part families - Parts classification and coding - coding structure – Optiz system, MICLASS system and CODE System.</p> <p>Process Planning: Introduction – Computer Assisted Process Planning (CAPP) – Types of CAPP - Variant type, Generative type – advantages of CAPP.</p> <p>Production Planning and Control (PPC): Definition – objectives - Computer Integrated Production management system – Master Production Schedule (MPS) – Capacity Planning – Materials Requirement Planning (MRP) – Manufacturing Resources Planning (MRP-II) – Shop Floor Control system (SFC) - Just In Time manufacturing philosophy (JIT) - Introduction to Enterprise Resources Planning (ERP).</p>	14
III	<p>CNC PROGRAMMING, RAPID PROTOTYPING</p> <p>CNC PART PROGRAMMING: Manual part programming - coordinate system – Datum points: machine zero, work zero, tool zero - reference points - NC dimensioning – G codes and M codes – linear interpolation and circular interpolation - CNC program procedure - sub-program – canned cycles - stock removal – thread cutting – mirroring – drilling cycle – pocketing.</p> <p>Rapid prototyping: Classification – subtractive – additive – advantages and applications - materials. Types - Stereo lithography (STL) – Fused deposition model (FDM) – Selective laser sintering (SLS) - three dimensional printing (3D) – Rapid tooling.</p>	14

IV	<p>COMPUTER INTEGRATED MANUFACTURING, FLEXIBLE MANUFACTURING SYSTEMS, AUTOMATIC GUIDED VEHICLE, ROBOT</p> <p>CIM: Introduction of CIM – concept of CIM - evolution of CIM – CIM wheel – Benefits – integrated CAD/CAM.</p> <p>FMS: Introduction – FMS components – FMS layouts – Types of FMS: Flexible Manufacturing Cell (FMC) – Flexible Turning Cell (FTC) – Flexible Transfer Line (FTL) – Flexible Machining System (FMS) – benefits of FMS - introduction to intelligent manufacturing system.</p> <p>AGV: Introduction – AGV - working principle – types – benefits.</p> <p>ROBOT: Definition – robot configurations – basic robot motion – robot programming method – robotic sensors – end effectors – mechanical grippers – vacuum grippers - Industrial applications of Robot: Characteristics - material transfer and loading – welding - spray coating - assembly and inspection.</p>	13
V	<p>CONCURRENT ENGINEERING, QUALITY FUNCTION DEPLOYMENT, PRODUCT DEVELOPMENT CYCLE, AUGMENTED REALITY.</p> <p>Concurrent Engineering: Definition – Sequential Vs Concurrent engineering – need of CE – benefits of CE.</p> <p>Quality Function Deployment (QFD): Definition – House of Quality (HOQ) – advantages – disadvantages. Steps in Failure Modes and Effects Analysis (FMEA) – Value Engineering (VE) – types of values – identification of poor value areas – techniques – benefits. Guide lines of Design for Manufacture and Assembly (DFMA).</p> <p>Product Development Cycle: Product Life Cycle - New product development processes.</p> <p>Augmented Reality (AR) – Introduction - concept – Applications.</p>	13

Text Books :

- 1) CAD/CAM/CIM , R.Radhakrishnan, S.Subramanian, New Age International Pvt. Ltd.
- 2) CAD/CAM , Mikell P.Groover, Emory Zimmers, Jr.Prentice Hall of India Pvt., Ltd.

Reference Books:

- 1) CAD/CAM Principles and Applications, Dr.P.N.Rao, Tata Mc Graw Hill Publishing Company Ltd.
- 2) CAD/CAM, Ibrahim Zeid, Mastering Tata McGraw-Hill Publishing Company Ltd., New Delhi.
- 3) Automation, Production Systems, and Computer-Integrated Manufacturing, Mikell P. Groover, Pearson Education Asia.
- 4) Computer control of manufacturing systems, Yoram Koren, McGraw Hill Book.



DIRECTORATE OF TECHNICAL EDUCATION
DIPLOMA IN AUTOMOBILE ENGINEERING

M SCHEME

2015 -2016 onwards

III YEAR

VI SEMESTER

32181 – TWO AND THREE WHEELER TECHNOLOGY
(ELECTIVE THEORY)

CURRICULUM DEVELOPMENT CENTRE

STATE BOARD OF TECHNICAL EDUCATION & TRAINING, TAMILNADU

M-SCHEME

(Implemented for the students Admitted from the Year 2015-2016 on wards)

Course Name : DIPLOMA IN AUTOMOBILE ENGINEERING

Course Code : 1021

Subject Code : 32181

Semester : VI

Subject Title : TWO AND THREE WHEELERS TECHNOLOGY

TEACHING AND SCHEME OF EXAMINATIONS:

No. of Weeks per Semester: 15 Weeks

Subject	Instructions		Examination			
	Hours/ Week	Hours/ Semester	Marks		Durations	
TWO AND THREE WHEELERS TECHNOLOGY	5	75	Internal Assessment	Board Examination	Total	3 Hrs
			25	75	100	

TOPICS AND ALLOCATION OF HOURS

UNIT	TOPIC	TIME ALLOTTED (Hrs.)
I	THE POWER UNIT AND FUEL SYSTEM	14
II	IGNITION SYSTEMS AND ELECTRICAL SYSTEM	14
III	CHASSIS AND SUB SYSTEMS	14
IV	BRAKES AND WHEELS	13
V	TWO AND THREE WHEELERS	13
	TEST & REVISION	7
TOTAL		75

**32181 – TWO AND THREE WHEELERS TECHNOLOGY
DETAILED SYLLABUS**

Contents: Theory

UNIT	Name of the topic	Hours
I	THE POWER UNIT AND FUEL SYSTEM Two stroke and four stroke - SI & CI engine Construction and Working - merits and demerits. Symmetrical and unsymmetrical valve & port timing diagrams- scavenging process- Fuel system –Different circuits in two wheeler fuel systems, fuel injection system and Lubrication system.	14
II	IGNITION SYSTEMS AND ELECTRICAL SYSTEM Ignition systems-Magneto coil, battery coil ignition system, Electronic ignition System - Starting system-Kick starter system– Self starter system. DTSI Speedo meter – Mechanical and Digital - Construction and working. Battery- Ratings in Two and Three wheelers. Layout of electrical system in two and three wheelers.	14
III	CHASSIS AND SUB SYSTEMS Main frame for two and three wheelers - Chassis –Types - Different drive systems for two wheelers and three wheelers – Clutch -Single plate, multiple plate wet and centrifugal clutch- Gear box- Constant mesh and sliding mesh- CVT -Continuously variable Transmission-Gear controls in two wheelers. Front and rear suspension systems- Shock absorbers. Panel meters and controls on handle bar of two and three wheelers.	14
IV	BRAKES AND WHEELS Drum brakes & Disc brakes for two and three wheelers - Construction and Working and its Types - Front and Rear brake link layouts. Brake actuation mechanism. Wheels -Spoked wheel, cast wheel, Disc wheel & its merits and demerits. Tyres and tubes Construction & its Types.	13
V	TWO AND THREE WHEELERS Two wheeler- case study of Sports bike, Motor cycles, Scooters and Mopeds – Parts, Components, maintenance and servicing. Three wheeler- Case study of Auto rickshaws, Pick up van, Delivery van Trailer- parts, components, maintenance and Servicing.	13

Text Book

1. Irving P.E Motor Cycle Engineering. Temple Press Book London.

Reference:

1. The Cycle Motor manual Temple Press Ltd London
2. Maintenance Manuals of Leading Two & Three Wheelers Manufacturers in India.



DIRECTORATE OF TECHNICAL EDUCATION
DIPLOMA IN AUTOMOBILE ENGINEERING

M SCHEME
2015 -2016 onwards

III YEAR
VI SEMESTER

**32182 – TRACTOR AND FARM EQUIPMENTS
(ELECTIVE THEORY)**

CURRICULUM DEVELOPMENT CENTRE

STATE BOARD OF TECHNICAL EDUCATION & TRAINING, TAMILNADU

M-SCHEME

(Implemented for the students Admitted from the Year 2015-2016 on wards)

Course Name : DIPLOMA IN AUTOMOBILE ENGINEERING
Course Code : 1021
Subject Code : 32182
Semester : VI
Subject Title : **TRACTOR AND FARM EQUIPMENTS**

TEACHING AND SCHEME OF EXAMINATIONS:

No. of Weeks per Semester : 15 Weeks

Subject	Instructions		Examination			Duration
	Hours/Week	Hours/Semester	Marks			
TRACTOR AND FARM EQUIPMENTS (ELECTIVE THEORY)	5	75	Internal Assessment	Board Examination	Total	3 Hrs
			25	75	100	

TOPICS AND ALLOCATION OF MARKS

UNIT	TOPIC	TIME ALLOTTED (Hrs.)
I	General Design of Tractors and Accessories	14
II	Ploughing Implements	14
III	Harvesting and Threshing Equipments	14
IV	Sprayers and Dusters	13
V	Maintenance of Tractors	13
	Test & Revision	7
TOTAL		75

**32182-TRACTOR AND FARM EQUIPMENTS
DETAILED SYLLABUS**

ELECTIVE THEORY

UNIT	Contents	Hours
I	General Design of Tractors and Accessories Classification of Tractors –Track laying tractor – heavy wheeled tractors – general purpose tractors – two wheeled tractors - Main components of Tractor – safety rules – Power Take Off Shaft – Belt pulley – Power Tiller. The tractor hydraulic system – operating principle.	14
II	Ploughing Implements Primary and Secondary Tillage equipments - DISC Plough – Mould Board Plough – Tiller and Harrows – Construction and maintenance – furrow mounted plough – plough controls - Mounting the plough – ploughing methods – systematic ploughing , round and round ploughing and one way ploughing - hitching – Three point linkage – Cage Wheel and its uses.-	14
III	Harvesting and Threshing Equipments Harvesting – conventional and Modern Harvesters – Threshing – Principle of Paddy Threshers construction and maintenance – combine – construction and advantages, disadvantages – safety precautions. Cultivation machinery – cultivators – effects and uses of cultivator – disc harrows – spring tine cultivator – seed harrows – effects and uses – chain harrows – effects and uses – rotary cultivator – uses. Corn drills – seed metering mechanisms – depth of sowing – fertilizer metering unit – checking the sowing rate. – Combine harvester – potato crop machinery – hand feed and automatic – sugar feet crop machinery.	14
IV	Sprayers and Dusters Classification of sprayers and dusters Manual and Power sprayers and Dusters – components of sprayers and dusters – different pumps, nozzles, used in sprayers – maintenance. Fertilizer distributors – rotating plate and flicker fertilizer unit – spinning disc type – the spreader mechanism – rate of application of manure. Haymaking machinery – Forage harvester – The Buckrake.	13
V	Maintenance of Tractors Daily Maintenance of Tractors – Maintenance of Tractors on hour basis – Trouble shooting of Tractor engines, clutch, Gear box – Major overhaul of engines. – Maintenance of the plough – routine maintenance of cultivating machinery – maintenance to grain drills – maintenance of fertilizer distributor – maintenance of farmyard manure spreaders.	13

Text Book

1) Elements of Agricultural Engineering Jagdishwar Sahay.

Reference:

1) Farm Tractor – Maintenance and Repair S.C.Jain, C.T.Raj, TATA MC Graw Hill.

2) Farm Machinery and Equipment – Smith & Wilkey, Tata MC Graw Hill.

3) Farm Machinery – C.Culpin.

4) Basic Farm Machinery, J M Shippen and J C Turner, Pergamon International Library.- Second edition



DIRECTORATE OF TECHNICAL EDUCATION
DIPLOMA IN AUTOMOBILE ENGINEERING

M SCHEME
2015 -2016 onwards

III YEAR
VI SEMESTER

32183 – AUTOMOBILE AIRCONDITIONING SYSTEM
(ELECTIVE THEORY)

CURRICULUM DEVELOPMENT CENTRE

STATE BOARD OF TECHNICAL EDUCATION & TRAINING, TAMILNADU

M-SCHEME

(Implemented for the students Admitted from the Year 2015-2016 on wards)

Course Name : DIPLOMA IN AUTOMOBILE ENGINEERING

Course Code : 1021

Subject Code : 32183

Semester : VI

Subject Title : AUTOMOBILE AIRCONDITIONING SYSTEM

TEACHING AND SCHEME OF EXAMINATIONS:

No. of Weeks per Semester: 15 Weeks

Subject	Instructions		Examination			Durations
	Hours/ Week	Hours/ Semester	Marks			
AUTOMOBILE AIRCONDITIONING SYSTEM	5	75	Internal Assessment	Board Examination	Total	3 Hrs
			25	75	100	

TOPICS AND ALLOCATION OF HOURS

UNIT	TOPIC	TIME ALLOTTED (Hrs.)
I	AIRCONDITIONING FUNDAMENTALS	14
II	AIRCONDITIONER HEATING SYSTEM	14
III	REFRIGERANTS	14
IV	AIR ROUTING & TEMPERATURE CONTROL	13
V	TROUBLE SHOOTING AND SERVICE	13
	TEST & REVISION	7
TOTAL		75

**32183 – AUTOMOBILE AIRCONDITIONING SYSTEM
DETAILED SYLLABUS**

Contents: Theory

UNIT	Name of the topic	Hours
I	AIRCONDITIONING FUNDAMENTALS Basic air-conditioning system –Location of air-conditioning components in a car- Schematic layout of a refrigeration system. Compressor components –Condenser and high pressure service ports. Thermostatic expansion valve-expansion valve calibration – controlling evaporator temperature-evaporator pressure regulator – Evaporator temperature regulator.	14
II	AIRCONDITIONER HEATING SYSTEM Automotive heaters – manually controlled air conditioner-Heater system-ford automatically controlled air conditioner and heating system – Automatic temperature control – Air-condition protection – Engine protection.	14
III	REFRIGERANTS Refrigerant Classification, Designation, Alternative Refrigerants, Global Warming Potential & Ozone Depleting Potential aspects. Handling of Refrigerants.	14
IV	AIR ROUTING & TEMPERATURE CONTROL Objectives-Evaporator care airflow through the dash board recirculation unit.Automatic temperature control – Duct system – Controlling flow – Vacuum reverse – Testing the air control and handling systems.	13
V	TROUBLE SHOOTING AND SERVICE Causes of air conditioner failure – Trouble shooting of air controlling system – Air conditioner maintenance and service – Servicing heater system. Removing and replacing components – leak testing- Compressor service.	13

TEXT BOOK:

1. William H Crouse and Donald L Anglin, Automotive air conditioning.McGraw-Hill Inc., 1990.

REFERENCE BOOKS:

1. Dwiggins, Automotive Air Conditioning,Thomson Asia,2002
2. Mitchell information services,Inc.,Mitchel Automatic Heating and air conditioning systems,
3. Paul Weiser, Automotive Airconditioning, Reston Publishing Co Inc., 1978.
4. MacDonald.K.L, Automotive Airconditioning, TheodoreAudel Series, 1978.
5. Goings.L.F., Automotive air conditioning, American Technical Services, 1974.



DIRECTORATE OF TECHNICAL EDUCATION
DIPLOMA IN AUTOMOBILE ENGINEERING

M SCHEME

2015 -2016 onwards

III YEAR

VI SEMESTER

**32064 – COMPUTER AIDED DESIGN AND
MANUFACTURING PRACTICAL**

CURRICULUM DEVELOPMENT CENTRE

STATE BOARD OF TECHNICAL EDUCATION & TRAINING, TAMILNADU

M-SCHEME

(Implemented for the students Admitted from the Year 2015-2016 on wards)

Course Name : DIPLOMA IN AUTOMOBILE ENGINEERING
Course Code : 1021
Subject Code : 32064
Semester : VI
Subject Title : COMPUTER AIDED DESIGN AND MANUFACTURING PRACTICAL

TEACHING AND SCHEME OF EXAMINATIONS:

No. of Weeks per Semester: 15 Weeks

Subject	Instructions		Examination			Duration
	Hours/ Week	Hours/ Semester	Marks			
Computer Aided Design and Manufacturing Practical	6	90	Internal Assessment	Board Examination	Total	3 Hrs
			25	75	100	

OBJECTIVES:

- Study of parametric modeling.
- Understand the part modeling and assembly of parts
- Create the views of the solid model and parts list.
- Study the working principle of CNC machines
- Study the datum points and offsets.
- Differentiate incremental System with absolute system
- Study the simulation software package.
- Write program and simulate in the Lathe software and Milling software.
- Prepare a part program, edit and execute in CNC Turning centre.
- Prepare a part program, edit and execute in CNC Machining centre.
- Produce components in the CNC Turning centre and CNC Machining centre.

PART A: Solid modeling (30 Hrs.)

Introduction

Part modelling - Datum Plane – constraint – sketch – dimensioning – extrude – revolve – sweep – blend – protrusion – extrusion – rib – shell – hole – round – chamfer – copy – mirror – assembly – align – orient.

Exercises

3D Drawing

1. Geneva Wheel
2. Bearing Block
3. Bushed bearing
4. Gib and Cotter joint
5. Screw Jack
6. Connecting Rod

Note: Print the orthographic view and sectional view from the above assembled 3D drawing.

PART B: CNC Programming and Machining (45 Hrs.)

Introduction:

1. Study of CNC lathe, milling.
2. Study of international standard codes: G-Codes and M-Codes
3. Format – Dimensioning methods.
4. Program writing – Turning simulator – Milling simulator, IS practice – commands menus.
5. Editing the program in the CNC machines.
6. Execute the program in the CNC machines.

Exercises

Note: Print the part program from the simulation software and make the component in the CNC machine.

CNC Turning Machine

Material: M.S / Aluminum / Acrylic fibre / Plastic

1. Using Linear and Circular interpolation - Create a part program and produce component in the Machine.

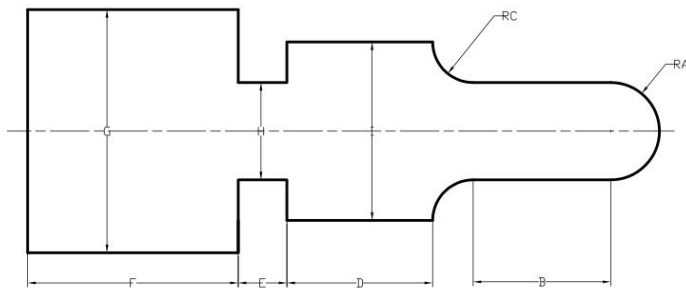

2. Using Stock removal cycle – Create a part program for multiple turning operations and produce component in the Machine.

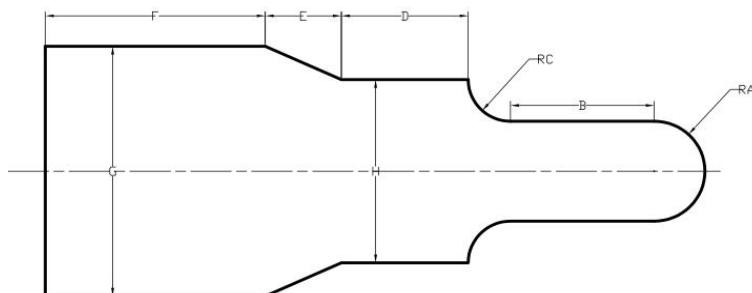

3. Using canned cycle - Create a part program for thread cutting, grooving and produce component in the Machine.

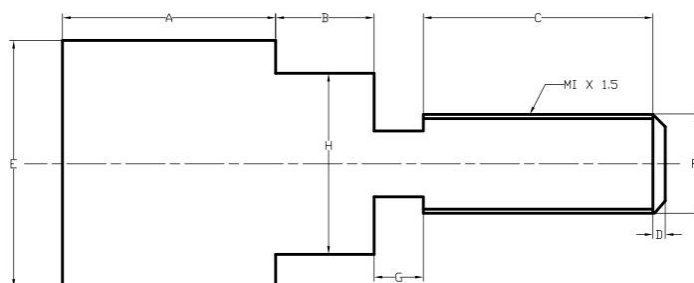

CNC Milling Machine

Material: M.S / Aluminum / acrylic fibre / plastic

4. Using Linear interpolation and Circular interpolation – Create a part program for grooving and produce component in the Machine.

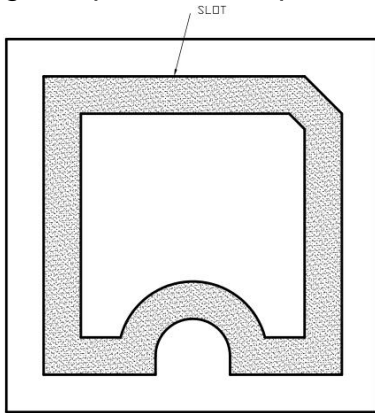

5. Using canned cycle - Create a part program for drilling, tapping, counter sinking and produce component in the Machine.

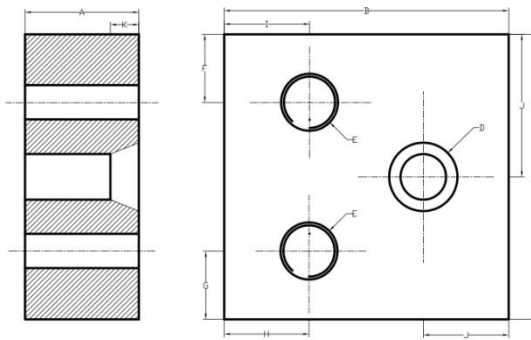

6. Using subprogram - Create a part program and produce component in the Machine.

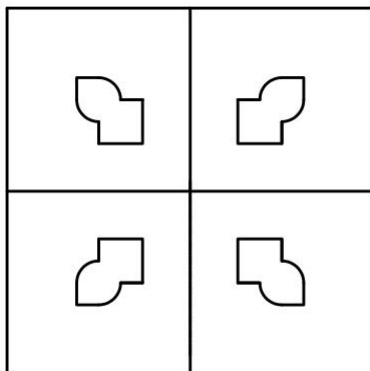

Reference:

CNC Programming & Operations, Mr.Sankar, Mr.Sathish and Mr.Balamurugan – Micro Publications, Tiruchy.

BOARD EXAMINATION

Note: All exercises should be completed. Two exercises should be carried out by selecting one exercise in each section. The printouts must be kept along with the examination paper.

Allocation of marks for Board Examination

PART –A: SOLID MODELING		35
Part modelling	:	15
Assembly	:	10
Printout	:	10
PART-B: CNC PROGRAMING		35
Program editing and creation	:	15
Component manufacturing	:	10
Finish	:	10
Viva voice	:	5
Total	:	75

LIST OF EQUIPMENTS

1. Personal computer - 30 Nos.
2. CNC programming software - Sufficient to the strength.
(Lathe and Milling)
3. Modelling package - Sufficient to the strength.
(Solid works / Pro-E / Catia / Unigraphics / Autocad etc...)
4. CNC Turning Machine - 1 No.
5. CNC Milling Machine - 1 No.
6. Laser Printer - 1 No.
7. Consumables - Sufficient quantity.



DIRECTORATE OF TECHNICAL EDUCATION
DIPLOMA IN AUTOMOBILE ENGINEERING

M SCHEME
2015 -2016 onwards

III YEAR
VI SEMESTER

32165 – AUTOMOBILE WOKSHOP PRACTICAL

CURRICULUM DEVELOPMENT CENTRE

STATE BOARD OF TECHNICAL EDUCATION & TRAINING, TAMILNADU

M-SCHEME

(Implemented for the students Admitted from the Year 2015-2016 on wards)

Course Name : DIPLOMA IN AUTOMOBILE ENGINEERING
Course Code : 1021
Subject Code : 32165
Semester : VI
Subject Title : **AUTOMOBILE WORKSHOP PRACTICAL**

TEACHING AND SCHEME OF EXAMINATIONS:

No. of Weeks per Semester: 15 Weeks

Subject	Instructions		Examination			Duration
	Hours/ Week	Hours/ Semester	Marks			
AUTOMOBILE WORKSHOP PRACTICAL	4	60	Internal Assessment	Board Examination	Total	3 Hrs
			25	75	100	

Objective

To impart the knowledge to learn the maintenance of the vehicle. This will create an opportunity to identify the fault and methods to rectify the fault.

PART – A

1. Valve lapping, valve run out, valve face out inspection, valve tip inspection and valve spring calibration
2. Re-boring and honing of cylinder liners.
3. Servicing and replacement of fuel tank, fuel filter and fuel pipes.
4. Engine compression and vacuum pressure testing, Clean, check and adjust spark plug of 2/3 wheeler.
5. Calibration of thermostat, checking of radiator cap, fan belt and coolant inspection by using Hydro-meter.
6. Testing of Fuel injector and nozzle.

PART – B

7. Servicing of drum brake , Skimming of brake drum and pad replacement.
8. Dismantle Wheel bearing, Steering stem& ball race, inspect and replace.
9. Replace control cable clutch, brake, accelerator cables and lubrication of chain drive – adjust clutch, brake play.
10. Servicing of disc brake including master cylinder, wheel cylinder checking, brake bleeding.
11. Multi plate Clutch service – disc inspection, drive and driven plates inspection and clutch springs.
12. Servicing of two wheeler gear box and replace oil.

BOARD EXAMINATION - DETAILED ALLOCATION

Note: Question paper should have two questions one from each part.

	Marks
PART A	45
PART B	25
Viva Voice	5
TOTAL	75

Resources required for 32165-AUTOMOBILE WORKSHOP PRACTICAL

1. Two wheeler – 2 nos.
 2. Four wheeler - 1 No.
 3. Engine Compression tester
 4. Hydro-meter
 5. Radiator pressure cap tester
 6. Honing / boring machine – 1 No.
 7. Engine lathe – 1 Nos
 8. Work table with 4 Bench vices – 5 Nos.
 9. Spanner set (6 to 32 mm) D/E and Ring - 5 sets
 10. Special tools (Wheel spanner ,Wrenches and Pliers etc.)- 2 sets
 11. Screw drivers - 5 sets (Various sizes)
 12. Grease gun – 5 nos.
 13. Feeler gauges – 5 nos.
 14. Steel rule - 5 nos.
 15. Adjustable spanner –5 nos.
 16. Socket spanner – 5 nos.
 17. Allenkey set – 5 nos.
 18. Thermometer
 19. Fuel injector and nozzle tester
- Other workshop tools.



DIRECTORATE OF TECHNICAL EDUCATION
DIPLOMA IN AUTOMOBILE ENGINEERING

M SCHEME

2015 -2016 onwards

III YEAR

VI SEMESTER

**32184 – TWO AND THREE WHEELER TECHNOLOGY
PRACTICAL
(ELECTIVE PRACTICAL)**

CURRICULUM DEVELOPMENT CENTRE

STATE BOARD OF TECHNICAL EDUCATION & TRAINING, TAMILNADU

M-SCHEME

(Implemented for the students Admitted from the Year 2015-2016 on wards)

Course Name : DIPLOMA IN AUTOMOBILE ENGINEERING
Course Code : 1021
Subject Code : 32184
Semester : VI
Subject Title : TWO AND THREE WHEELER TECHNOLOGY PRACTICAL

TEACHING AND SCHEME OF EXAMINATIONS:

No. of Weeks per Semester: 15 Weeks

Subject	Instructions		Examination			Durations
	Hours/Week	Hours/Semester	Marks			
TWO AND THREE WHEELER TECHNOLOGY PRACTICAL	4	60	Internal Assessment	Board Examination	Total	3 Hrs
			25	75	100	

Note: All the experiments should be conducted and examination also to be conducted for all the exercises.

LIST OF EXPERIMENTS

1. Dismantle, check and assemble the radiator, water pump of a three wheeler
2. Remove and replace the oil filter, oil and inspect the oil pump, clogged oil lines, oil passages in three wheelers
3. Dismantle and assemble the clutch used in 2&3 wheelers
4. Adjust the clutch free play, throttle cable and inspect the common troubles and causes in 2&3 wheelers
5. Overhaul and lubricate the gear box of 2&3 wheeler
6. Dismantle, lubricate and assemble the propeller shaft and differential
7. Dismantle, lubricate and assemble the rear axle of the 3 wheeler
8. Check frame alignment, dismantle and assemble the leaf spring assembly
9. Dismantle and assemble the front suspension and rear suspension of a motor cycle
10. Remove the tyre, lubricate bearings, refit and adjust the chain of a two wheeler

11. Dismantle, Service and assemble the disc brake system – Master cylinder, Wheel Cylinder, Caliper and brake pad of a two wheeler
12. Dismantle service and assemble the mechanical brake system of a 2& 3 wheeler.

BOARD EXAMINATION
SCHEME OF EXAMINATION

Note: One question should be given. Students should dismantle and assemble the components after verification by the examiner.

Procedure	20
Dismantling	20
Assembly	20
Tool handling	10
Viva Voice	5
TOTAL	75

Resources required

Two wheeler - 3 Nos.

Three wheeler – 2 Nos.

Special tools – 5 sets

Each experiment separate components are required.

Sufficient quantity of tools.

Proper material handling devices.



DIRECTORATE OF TECHNICAL EDUCATION
DIPLOMA IN AUTOMOBILE ENGINEERING

M SCHEME

2015 -2016 onwards

III YEAR

VI SEMESTER

**32185 – TRACTOR AND FARM EQUIPMENTS
PRACTICAL
(ELECTIVE PRACTICAL)**

CURRICULUM DEVELOPMENT CENTRE

STATE BOARD OF TECHNICAL EDUCATION & TRAINING, TAMILNADU

M-SCHEME

(Implemented for the students Admitted from the Year 2015-2016 on wards)

Course Name : DIPLOMA IN AUTOMOBILE ENGINEERING
Course Code : 1021
Subject Code : 32185
Semester : VI
Subject Title : **TRACTOR AND FARM EQUIPMENTS PRACTICAL**

TEACHING AND SCHEME OF EXAMINATIONS:

No. of Weeks per Semester : 15 Weeks

Subject	Instructions		Examination			Duration
	Hours/ Week	Hours/ Semester	Marks			
TRACTORS AND FARM EQUIPMENTS PRACTICAL	4	60	Internal Assessment	Board Examination	Total	3 Hrs
			25	75	100	

List of Experiments

1. Driving the Tractor – Driving Practice only.
2. Hitching the given implement with the tractor by three point linkage and unhitching practice.
3. Ploughing practice with Mould Board Plough.
4. Ploughing practice with DISC harrows.
5. Ploughing practice with Tiller.
6. Power Tiller – study, its usage in the field and maintenance.
7. Cage wheel – fitting the cage wheel after removing the wheels from Tractor.
8. Spraying practice with power sprayer and its maintenance.
9. Tractor maintenance Schedule.

BOARD EXAMINATION - DETAILED ALLOCATION

Note: One question should be given.

Procedure	20
Exercise	30
Handling	20
Viva Voice	5
TOTAL	75

Resources required for 32185- Tractors and Farm Equipments Practical

Tractor – 1 No.

Power triller – 1 No.

Ploughing kits

Power sprayer – 1 No.

Special tools – 5 sets



DIRECTORATE OF TECHNICAL EDUCATION
DIPLOMA IN AUTOMOBILE ENGINEERING

M SCHEME

2015 -2016 onwards

III YEAR

VI SEMESTER

**32186 – AUTOMOBILE AIRCONDITIONING SYSTEM
PRACTICAL
(ELECTIVE PRACTICAL)**

CURRICULUM DEVELOPMENT CENTRE

STATE BOARD OF TECHNICAL EDUCATION & TRAINING, TAMILNADU

M-SCHEME

(Implemented for the students Admitted from the Year 2015-2016 on wards)

Course Name : DIPLOMA IN AUTOMOBILE ENGINEERING
Course Code : 1021
Subject Code : 32186
Semester : VI
Subject Title : AUTOMOBILE AIR CONDITIONING SYSTEM PRACTICAL

TEACHING AND SCHEME OF EXAMINATIONS:

No. of Weeks per Semester : 15 Weeks

Subject	Instructions		Examination			Durations
	Hours/Week	Hours/Semester	Marks			
AUTOMOBILE AIR CONDITIONING SYSTEM PRACTICAL	4	60	Internal Assessment	Board Examination	Total	3 Hrs
			25	75	100	

Note: All the experiments should be conducted and examination also to be conducted for all the exercises.

OBJECTIVES :

- *Identify the various tools used in R & AC.
- *Demonstrate the construction and working of Window air conditioner.
- *Demonstrate the construction and working of car air conditioner.
- *Set parameters for comfortable operation of air conditioner.
- *Perform servicing of automobile air conditioner.

PART – A

EXERCISES

1. BASIC REFRIGERATION WORKSHOP OPERATION:

(a)Copper and steel tubing

- To study the various sizes of copper and steel tubing.
- To study the various tools used for operations.

-To become familiar with various operations and copper and steel tubing – Flaring, Swaging.

(b)Soldering methods used in R & AC.

2. TO STUDY THE CONSTRUCTION FEATURES OF THE FOLLOWING:

(a)Window air conditioner (b) Split air conditioner (c) car air conditioner

3. PROPER METHODS OF SETTING AND ADJUSTING OF

(a)Thermostats

(b)Low pressure and high pressure cutouts

(c)Thermostatic expansion valve

(d)Automatic expansion valve

PART – B

EXERCISES

1. TEST PROCEDURES.

(I) To evaluate the condition of the car air conditioner by using electrical measurements with

(a)Thermostatic expansion valve

(b) Magnetic clutch

(c) Heater

2. SERVICE PROCEDURES.

I. To change refrigerant from storage cylinder to service cylinder.

ii.To evacuvate the entire system.

iii.To pump down the system.

iv.To purge the air from the system.

v.To locate the leaks in the system.

vi.To charge the system.

Vii.To check the magnetic clutch function.

viii. Tracing the common failures in air conditioning system and their remedies.

**BOARD EXAMINATION
SCHEME OF EXAMINATION**

Note: Question paper should have two questions, consist one from each part.

PART A	35
PART B	35
Viva Voice	5
TOTAL	75



DIRECTORATE OF TECHNICAL EDUCATION
DIPLOMA IN AUTOMOBILE ENGINEERING

M SCHEME
2015 -2016 onwards

III YEAR
VI SEMESTER

32167 – PROJECT WORK

CURRICULUM DEVELOPMENT CENTRE

STATE BOARD OF TECHNICAL EDUCATION & TRAINING, TAMILNADU

M-SCHEME

(Implemented for the students Admitted from the Year 2015-2016 on wards)

Course Name : DIPLOMA IN AUTOMOBILE ENGINEERING
Course Code : 1021
Subject Code : 32167
Semester : VI
Subject Title : Project Work

TEACHING AND SCHEME OF EXAMINATIONS:

No. of Weeks per Semester: 15 Weeks

Subject	Instruction		Examination		
	Hours/ Week	Hours/ Semester	Assessment Marks		
			Internal	Board Exam	Total
PROJECT WORK	4	60	25	75	100

Minimum Marks for Pass is 50 out of which minimum 35 marks should be obtained out of 75 marks in the board Examination alone.

OBJECTIVES:

- Implement the theoretical and practical knowledge gained through the curriculum into an application suitable for a real practical working environment preferably in an industrial environment
- Get exposure on industrial environment and its work ethics.
- Understand what entrepreneurship is and how to become an entrepreneur.
- Learn and understand the gap between the technological knowledge acquired through curriculum and the actual industrial need and to compensate it by acquiring additional knowledge as required.
- Carry out cooperative learning through synchronous guided discussions within the class in key dates, asynchronous document sharing and discussions, as well as to prepare collaborative edition of the final project report.
- Understand the facts and importance of environmental management.

- Understand and gain knowledge about disaster management

INTERNAL ASSESSMENT:

The internal assessment should be calculated based on the review of the progress of the work done by the student periodically as follows.

Detail of assessment	Period of assessment	Max. Marks
First Review	6 th week	10
Second Review	12 th week	10
Attendance	Entire semester	5
Total		25

EVALUATION FOR BOARD EXAMINATION:

Details of Mark allocation	Max Marks
Marks for Report Preparation, Demo, Viva-voce	65
Marks for answers of 4 questions which is to be set by the external examiner from the given question bank consisting of questions in the following two topics Disaster Management and Environmental Management. Out of four questions two questions to appear from each of the above topics i.e. 2 questions x 2 topics = 4 questions 4 questions x 2 ½ marks = 10 Marks	10
Total	75

DETAILED SYLLABUS

ENVIRONMENTAL & DISASTER MANAGEMENT

1. ENVIRONMENTAL MANAGEMENT

Introduction – Environmental Ethics – Assessment of Socio Economic Impact – Environmental Audit – Mitigation of adverse impact on Environment – Importance of Pollution Control – Types of Industries and Industrial Pollution.

Solid waste management – Characteristics of Industrial wastes – Methods of Collection, transfer and disposal of solid wastes – Converting waste to energy – Hazardous waste management Treatment technologies.

Waste water management – Characteristics of Industrial effluents – Treatment and disposal methods – Pollution of water sources and effects on human health.

Air pollution management – Sources and effects – Dispersion of air pollutants – Air pollution control methods – Air quality management.

Noise pollution management – Effects of noise on people – Noise control methods.

2. DISASTER MANAGEMENT

Introduction – Disasters due to natural calamities such as Earthquake, Rain, Flood, Hurricane, Cyclones etc – Man made Disasters – Crisis due to fires, accidents, strikes etc – Loss of property and life..

Disaster Mitigation measures – Causes for major disasters – Risk Identification – Hazard Zones – Selection of sites for Industries and residential buildings – Minimum distances from Sea – Orientation of Buildings – Stability of Structures – Fire escapes in buildings - Cyclone shelters – Warning systems.

Disaster Management – Preparedness, Response, Recovery – Arrangements to be made in the industries / factories and buildings – Mobilization of Emergency Services - Search and Rescue operations – First Aids – Transportation of affected people – Hospital facilities – Fire fighting arrangements – Communication systems – Restoration of Power supply – Getting assistance of neighbors / Other organizations in Recovery and Rebuilding works – Financial commitments – Compensations to be paid – Insurances – Rehabilitation.

LIST OF QUESTIONS

1. ENVIRONMENTAL MANAGEMENT

1. What is the responsibility of an Engineer-in-charge of an Industry with respect to Public Health?
2. Define Environmental Ethic.
3. How Industries play their role in polluting the environment?
4. What is the necessity of pollution control? What are all the different organizations you know, which deal with pollution control?
5. List out the different types of pollutions caused by a Chemical / Textile / Leather / Automobile / Cement factory.
6. What is meant by Hazardous waste?
7. Define Industrial waste management.
8. Differentiate between garbage, rubbish, refuse and trash based on their composition and source.

9. Explain briefly how the quantity of solid waste generated in an industry could be reduced.
10. What are the objectives of treatments of solid wastes before disposal?
11. What are the different methods of disposal of solid wastes?
12. Explain how the principle of recycling could be applied in the process of waste minimization.
13. Define the term 'Environmental Waste Audit'.
14. List and discuss the factors pertinent to the selection of landfill site.
15. Explain the purpose of daily cover in a sanitary landfill and state the minimum desirable depth of daily cover.
16. Describe any two methods of converting waste into energy.
17. What actions, a local body such as a municipality could take when the agency appointed for collecting and disposing the solid wastes fails to do the work continuously for number of days?
18. Write a note on Characteristics of hazardous waste.
19. What is the difference between municipal and industrial effluent ?
20. List few of the undesirable parameters / pollutants anticipated in the effluents from oil refinery industry / thermal power plants / textile industries / woolen mills / dye industries / electroplating industries / cement plants / leather industries (any two may be asked)
21. Explain briefly the process of Equalization and Neutralization of waste water of varying characteristics discharged from an Industry.
22. Explain briefly the Physical treatments "Sedimentation" and "Floatation" processes in the waste water treatment.
23. Explain briefly when and how chemical / biological treatments are given to the waste water.
24. List the four common advanced waste water treatment processes and the pollutants they remove.
25. Describe refractory organics and the method used to remove them from the effluent.
26. Explain biological nitrification and de-nitrification.
27. Describe the basic approaches to land treatment of Industrial Effluent.
28. Describe the locations for the ultimate disposal of sludge and the treatment steps needed prior to ultimate disposal.
29. List any five Industries, which act as the major sources for Hazardous Air Pollutants.
30. List out the names of any three hazardous air pollutants and their effects on human health.
31. Explain the influence of moisture, temperature and sunlight on the severity of air pollution effects on materials.
32. Differentiate between acute and chronic health effects from Air pollution.
33. Define the term Acid rain and explain how it occurs.
34. Discuss briefly the causes for global warming and its consequences

35. Suggest suitable Air pollution control devices for a few pollutants and sources.
36. Explain how evaporative emissions and exhaust emissions are commonly controlled.
37. What are the harmful elements present in the automobile smokes? How their presence could be controlled?
38. What is the Advantage of Ozone layer in the atmosphere? State few reasons for its destruction.
39. Explain the mechanism by which hearing damage occurs.
40. List any five effects of noise other than hearing damage.
41. Explain why impulsive noise is more dangerous than steady state noise.
42. Explain briefly the Source – Path – Receiver concept of Noise control.
43. Where silencers or mufflers are used ? Explain how they reduce the noise.
44. Describe two techniques to protect the receiver from hearing loss when design / redress for noise control fail.
45. What are the problems faced by the people residing along the side of a railway track and near to an Airport? What provisions could be made in their houses to reduce the problem?

2. DISASTER MANAGEMENT

1. What is meant by Disaster Management? What are the different stages of Disaster management?
2. Differentiate Natural Disasters and Man made Disasters with examples.
3. Describe the necessity of Risk identification and Assessment Surveys while planning a project.
4. What is Disasters recovery and what does it mean to an Industry?
5. What are the factors to be considered while planning the rebuilding works after a major disaster due to flood / cyclone / earthquake? (Any one may be asked)
6. List out the public emergency services available in the state, which could be approached for help during a natural disaster.
7. Specify the role played by an Engineer in the process of Disaster management.
8. What is the cause for Earthquakes? How they are measured? Which parts of India are more vulnerable for frequent earthquakes?
9. What was the cause for the Tsunami 2004 which inflicted heavy loss to life and property along the coast of Tamilnadu ? Specify its epicenter and magnitude.
10. Specify the Earthquake Hazard Zones in which the following towns of Tamilnadu lie: (a) Chennai (b) Nagapattinam (c) Coimbatore (d) Madurai (e) Salem.
11. Which parts of India are experiencing frequent natural calamities such as (a) heavy rain fall (b) huge losses due to floods (c) severe cyclones
12. Define basic wind speed. What will be the peak wind speed in (a) Very high damage risk zone – A, (b) High damage risk zone, (c) Low damage risk zone.

13. Specify the minimum distance from the Sea shore and minimum height above the mean sea level, desirable for the location of buildings.
14. Explain how the topography of the site plays a role in the disasters caused by floods and cyclones.
15. Explain how the shape and orientation of buildings could reduce the damages due to cyclones.
16. What is a cyclone shelter ? When and where it is provided ? What are its requirements ?
17. What Precautionary measures have to be taken by the authorities before opening a dam for discharging the excess water into a canal/river ?
18. What are the causes for fire accidents ? Specify the remedial measures to be taken in buildings to avoid fire accidents.
19. What is a fire escape in multistoried buildings ? What are its requirements ?
20. How the inmates of a multistory building are to be evacuated in the event of a fire/Chemical spill/Toxic Air Situation/ Terrorist attack, (any one may be asked).
21. Describe different fire fighting arrangements to be provided in an Industry.
22. Explain the necessity of disaster warning systems in Industries.
23. Explain how rescue operations have to be carried out in the case of collapse of buildings due to earthquake / blast / Cyclone / flood.
24. What are the necessary steps to be taken to avoid dangerous epidemics after a flood disaster?
25. What relief works that have to be carried out to save the lives of workers when the factory area is suddenly affected by a dangerous gas leak / sudden flooding ?
26. What are the difficulties faced by an Industry when there is a sudden power failure? How such a situation could be managed?
27. What are the difficulties faced by the Management when there is a group clash between the workers? How such a situation could be managed?
28. What will be the problems faced by the management of an Industry when a worker dies because of the failure of a mechanical device due to poor maintenance? How to manage such a situation ?
29. What precautionary measures have to be taken to avoid accidents to labourers in the Industry in a workshop / during handling of dangerous Chemicals / during construction of buildings / during the building maintenance works.
30. Explain the necessity of medical care facilities in an Industry / Project site.
31. Explain the necessity of proper training to the employees of Industries dealing with hazardous products, to act during disasters.
32. What type of disaster is expected in coal mines, cotton mills, Oil refineries, ship yards and gas plants?
33. What is meant by Emergency Plan Rehearsal? What are the advantages of such Rehearsals?
34. What action you will take when your employees could not reach the factory site because of continuous strike by Public Transport workers?

35. What immediate actions you will initiate when the quarters of your factory workers are suddenly flooded due to the breach in a nearby lake / dam, during heavy rain?
36. What steps you will take to avoid a break down when the workers union of your Industry have given a strike notice?
37. List out few possible crisis in an organization caused by its workers? What could be the part of the middle level officials in managing such crisis?
38. What types of warning systems are available to alert the people in the case of predicted disasters, such as floods, cyclone etc.
39. Explain the necessity of Team work in the crisis management in an Industry / Local body.
40. What factors are to be considered while fixing compensation to the workers in the case of severe accidents causing disability / death to them?
41. Explain the legal / financial problems the management has to face if safety measures taken by them are found to be inadequate.
42. Describe the importance of insurance to men and machinery of an Industry dealing with dangerous jobs.
43. What precautions have to be taken while storing explosives in a match/ fire crackers factory?
44. What are the arrangements required for emergency rescue works in the case of Atomic Power Plants?
45. Why residential quarters are not constructed nearer to Atomic Power Plants?
